



ENGINEERED  
BUILDING  
PRODUCTS

futurebuild

STRUCTURAL  
LVL

hySPAN

## SPAN TABLES FOR RESIDENTIAL BUILDING

NOW AVAILABLE H2-S TREATED  
TO PROTECT AGAINST TERMITES†



# contents

## Contents

### Introduction

Page N°

Application	3
Some information about Hyspan and its use	3
Terminology used in these tables	6
Your guarantee of quality	8
Structural Certification	9
Technical Support	9

### Table N° Description

<b>Bearers</b>	
1	- Supporting Floor Loads only 11
2	- Supporting Single or Upper Storey Load Bearing Walls 12
3	- Supporting Two Storey Load Bearing Walls 14
<b>Bearers for Pole Frame Construction</b>	
4	- Supporting Floor Loads only 17
5	- Supporting Single or Upper Storey Load Bearing Walls 19
<b>Floor Joists</b>	
6	- Supporting Floor Loads only 21
7	- For Tiled Floors or Floors Supporting Heavy Furniture 22
8	- Supporting Parallel Load Bearing Walls Over Openings 23
<b>Lintels</b>	
9	- In Single or Upper Storey Load Bearing External Walls 25
10	- In Lower Storey Load Bearing External Walls 26
11	- Supporting Truncated Girder Truss 29
12	- Supporting Strutting Beams. Strutting Beams Supporting Underpurlins and Hanging Beams 31
<b>Ceiling Joists</b>	
13	- Supporting Ceiling Lining only 32
<b>Hanging Beams</b>	
14	- Supporting Ceiling Joists 33
<b>Counter Beams</b>	
15	- Supporting Hanging Beams 34
<b>Strutting Beams</b>	
16	- Supporting Underpurlins 36
17	- Supporting Underpurlins and Ceiling 39
18	- Supporting Underpurlins and Hanging Beams 41

Table N°	Description	Page N°
19	<b>Underpurlins</b>	42
	<b>Hip Rafters or Valley Rafters</b>	
20	- Supporting Underpurlins and Rafters	43
21	- Supporting Rafters only	45
	<b>Rafters</b>	
22	- Design Wind Speed 33m/s	47
23	- Design Wind Speed 41m/s	50
24	- Widely Spaced - Design Wind Speed 33m/s	53
25	- Widely Spaced - Design Wind Speed 41m/s	55
	<b>Roof Beams</b>	
26	- Ridge, Intermediate, Eave and Bressumer Beams	58
	<b>Verandah Beams</b>	
27	- Design Wind Speed 33m/s	60
28	- Design Wind Speed 41m/s	62
	<b>Garage Roof Pitching Beams</b>	
29	- For Trussed or Pitched Roofs	64
	<b>Garage Roof Strutting Beams</b>	
30	- Strutting Beam Beneath Ceiling	67
	<b>Appendix</b>	
	Roof Slope Conversion	68
	Mass of typical framing timbers	68
<b>Inside Back Cover</b>		
	Hyspan Specification	
	Standard Hyspan sections and their approximate mass	



Hyspan the engineered solution for mo



*Continuous Hyspan being manufactured at Nangwarry in South Australia.*

# Modern housing design and construction.

Hyspan is laminated veneer lumber (LVL) having high structural reliability and consistent dimensional accuracy. Its consistency allows builders and designers to specify Hyspan with confidence. Hyspan is readily available in a range of thicknesses including 36 mm, 45 mm, 63 mm and 75 mm with depths from 95 mm to 600 mm.

## APPLICATION

The span tables are intended to be used by designers or builders to select the appropriate sizes of Hyspan for members used in the framing of houses and similar buildings.

The tabulated data given only applies for Hyspan members installed in accordance with traditionally recognised framing practice as described in AS 1684 National Timber Framing Code, Timber Framing Manuals published by various state timber trade associations and other installation information contained in this book.

### Wind Loading

Except as noted below, the tables given in this book are suitable for applications involving design winds speeds up to 41 m/s in both cyclonic and non-cyclonic wind regions.

For rafters and verandah beams, separate tables are included for both 33 m/s and 41 m/s design wind speeds.

For floor joists, bearers or lower storey lintels the tables contained can be used for cases where the design wind speed is up to 60 m/s (cyclonic).

For other applications involving wind speeds greater than 41 m/s designers should refer to the separate Carter Holt Harvey publication, Hyspan - Span Tables for High Wind Areas, pictured below.



## SOME INFORMATION ABOUT HYSPAN AND ITS USE

Hyspan is laminated veneer lumber (LVL) intended for structural use and conforming with the requirements of AS/NZS 4357 Structural Laminated Veneer Lumber.

### Manufacture

Hyspan is manufactured by laminating plantation radiata pine veneer, using phenolic adhesive, in a continuous assembly in which the grain direction of all veneers is orientated in the longitudinal direction. It is pressed as a 1.2 m nominal width continuous billet in various standard thicknesses, docked to any specified length and then ripped into standard widths for use as structural beams etc.

The standard sizes for Hyspan and a comprehensive product specification are detailed on the inside back cover of this book.

### Structural Properties

The structural properties for Hyspan have been determined by testing in accordance with the requirements of AS/NZS 4357. The properties given below are therefore suitable for structural design performed in accordance with AS 1720.1-1997, Timber structures, Part 1: Design methods.

LIMIT STATE PROPERTIES FOR DESIGN WITH HYSPAN		
<b>Elastic Moduli</b>		
Modulus of elasticity	E	13,200 MPa
Modulus of rigidity	G	660 MPa
<b>Characteristic Strengths</b>		
Bending	$f'_b$	48 MPa
Tension parallel to grain	$f'_t$	33 MPa
Compression parallel to grain	$f'_c$	45 MPa
Shear in beams	$f'_s$	5.3 MPa
Compression perpendicular to grain	$f'_p$	12 MPa
Shear at joint details	$f'_{sj}$	5.3 MPa
<b>Joint group</b>	JD4	

Notes: Hyspan has not been assigned an F grade. Specification of the name Hyspan signifies the applicability of the properties given in the table above and meets the stress grade identification requirements of AS 1720.

Further design information and guidance for Limit State Design is available in the futurebuild publication 'Limit States Design with Hyspan'.

## STRUCTURAL RELIABILITY

Hyspan is manufactured by laminating various grades of veneer in a predetermined pattern in order to impart predictable and reliable structural properties. The uniformity of Hyspan is the key to its high strength and stiffness properties and its reputation for reliable and predictable performance. It is the reliability of Hyspan that makes it a genuine engineering material suitable for high load, high consequence of failure applications such as highway bridges and large span portal frames.

For ordinary applications the reliability of Hyspan, illustrated graphically below, rewards specifiers and builders with the certain confidence of meeting customer expectations and reduction in the incidence of expensive and disruptive call backs.

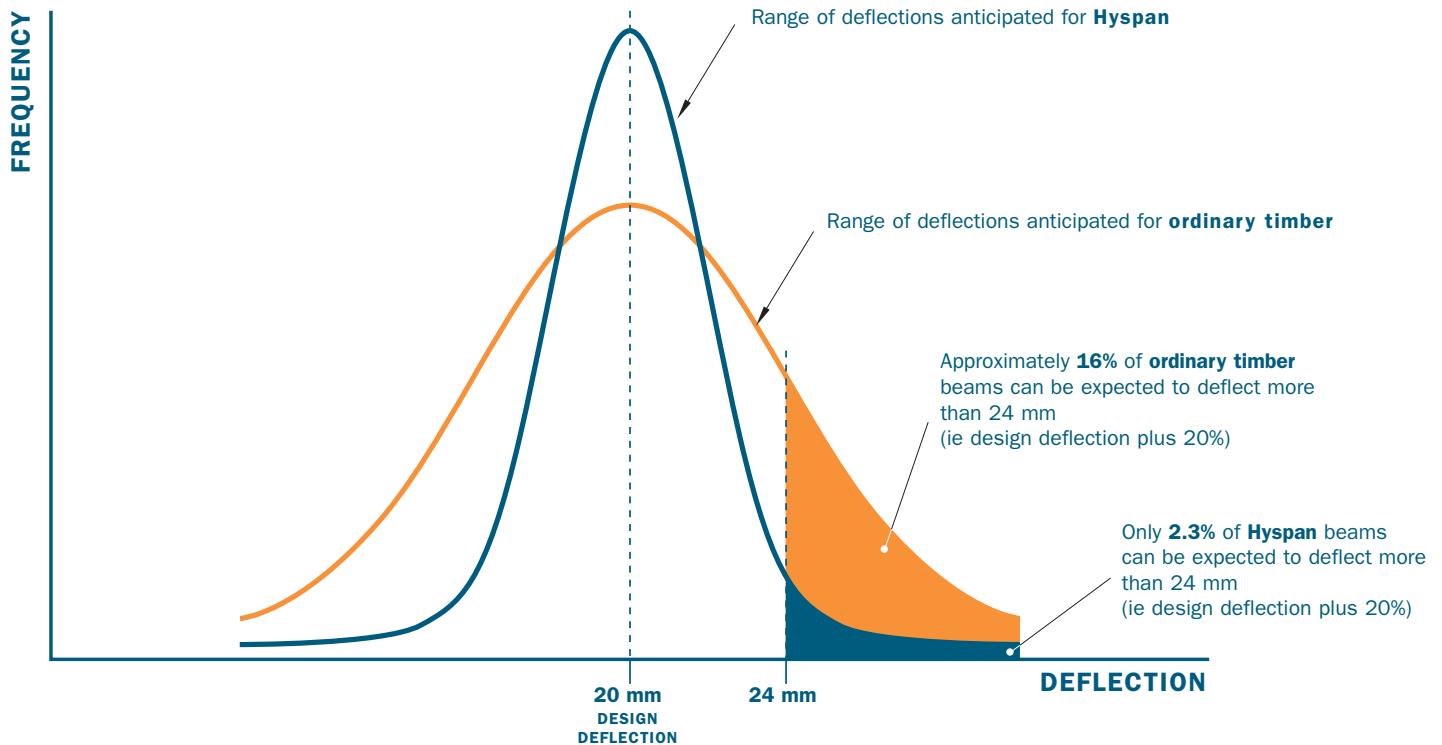

### FIXING OF HYSPAN

Hyspan may be nailed, bolted or screw fixed exactly the same way as seasoned timber. For installation and performance of fasteners there is no need to distinguish between fasteners installed into either the face or edge (see diagram). Standard edge and end distances and spacings between fasteners appropriate for seasoned softwood timber may be used.

In order to determine the load carrying capacity of nail, screw or bolt fasteners used with Hyspan, Joint Group JD4 properties shall be taken to apply.

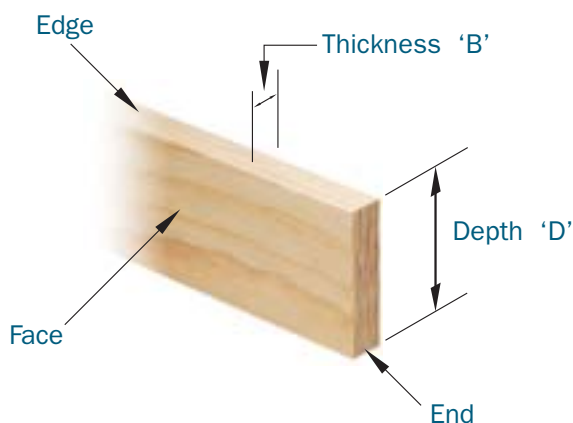

### RIP SAWING HYSPAN

Unlike graded timber, Hyspan may be rip sawn through the thickness to the smaller standard section depths given in these span tables without affecting the basic strength properties. Care should be taken however, to comply with the no negative tolerance specification (i.e. do not cut undersize) if the maximum spans given in these tables are to apply.

Rip sawing through the depth to produce sections of reduced thickness may adversely affect strength properties and is therefore **not** recommended.

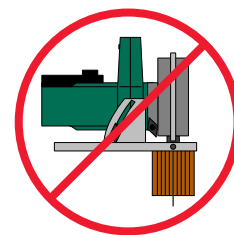

*Do not rip through the depth.*





*Rip sawing through the thickness.*

## DURABILITY

Hyspan is manufactured from Radiata Pine veneer bonded with phenolic adhesive. Whilst the phenolic bond is fully waterproof (Type A or Marine bond), the Radiata Pine is Durability Class 4 and may decay if it is exposed to high levels of moisture for protracted periods. Exposure to weather during normal construction periods is not a cause for concern.

**Sub-floor Applications.** Good building practice ensures that raised timber floors are well ventilated underneath. This is intended to eliminate the possibility of decay for sub-floor members and flooring alike. Hyspan may be safely used where standard practices for ventilation and clearance are followed.



## Carpents, Verandahs, Rafter Overhangs.

Components used in roofed over structures may occasionally be wetted by wind driven rain. Provided Hyspan does not remain continuously wet for periods of weeks or months, decay is not likely. Painting or staining of such partially weather exposed timbers is recommended.

**External Use.** Hyspan is not recommended for fully weather exposed applications such as pergolas or under decks etc unless it has been suitably preservative treated to H3 level (refer AS 1604), painted or stained, and is appropriately installed and maintained.

Where H3 preservative treated Hyspan is used for external applications it is recommended that detailed guidelines for installation and advice regarding the expectations of durability performance for the specific treatment type, treatment process, installation and exposure conditions are obtained from the preservative treating organisation or supplier. Furthermore, information regarding the safe handling and disposal of preservative treated residues should also be obtained from the treatment business or supplier.

## USING DOUBLE SECTIONS

Where double sections are specified these need to be securely nail laminated. This does not apply for bearers used in pole frame construction - see pages 16 - 19.

Whilst nail lamination may ordinarily be satisfactorily achieved using the procedures given in AS 1684 the fixing will often not be adequate if double sections are required to support incoming members face fixed on one side.

In addition experience indicates it is advantageous to provide greater rigidity in fixing and to limit the entry of water between laminations during construction. Moisture between laminates tends to cause laminates to cup and separate. In order to meet these requirements the following detail for jointing double sections of Hyspan is recommended.

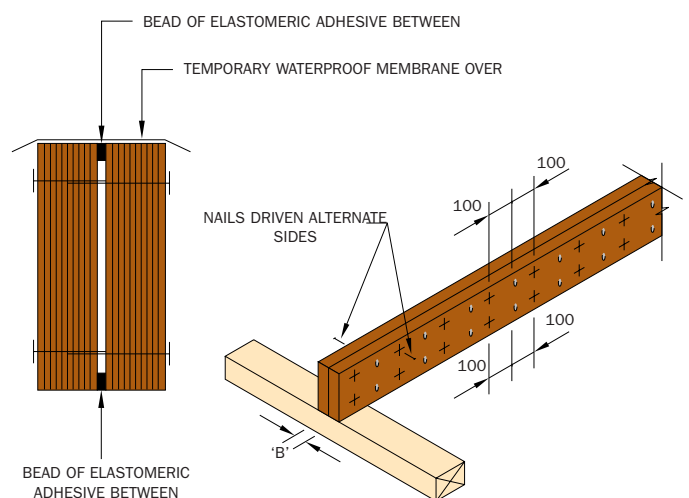

SECTION SIZE "B"	MINIMUM NAIL DIA	MINIMUM NAIL LENGTH
36	3.06 mm	75 mm
45	3.30 mm	90 mm
63	3.30 mm	100 mm

Vertical Lamination Detail

## STORAGE OF HYSPAN

The following recommendations regarding storage are made in order to ensure that the full benefits of Hyspan as a dry, straight and true material are available at the time of installation.

1. Stack on level bearers to keep flat and straight.
  2. Stack well clear of the ground for good ventilation.
  3. Store under cover to keep dry prior to installation.
- Note: After installation, exposure to sun and rain for normal periods of construction is not a cause for concern.



## TERMINOLOGY USED IN THESE TABLES

### SPAN

For the purpose of using these tables, span may be interpreted as the clear distance between supports measured along the beam.

**Single Span Beams** are beams supported at two points only.

**Continuous Span Beams** are beams supported at three or more points along their length.

Continuous span values given in the tables should only be used where:-

- a) The beam is not notched or partially cut through at internal support points and,
- b) If the spans are not equal, the largest span is not greater than twice the smallest adjacent span.

However if either of the above conditions are not met, use the single span tables for the purpose of obtaining the appropriate size.

**Overhang Span.** Sometimes referred to as cantilever, overhang is the distance from the face of the support to the free end of the beam, measured along the beam as illustrated.

For beams with overhangs, the backspan (see diagram) should be at least twice the length of the overhang in order to limit uplift forces on the backspan support.

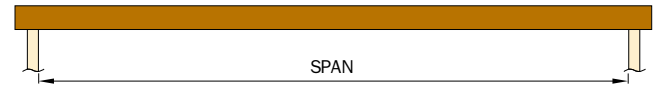

Single Span Beam

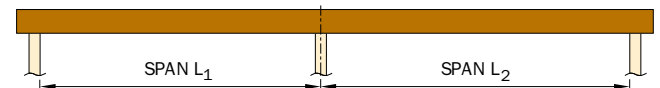

Continuous Span Beam

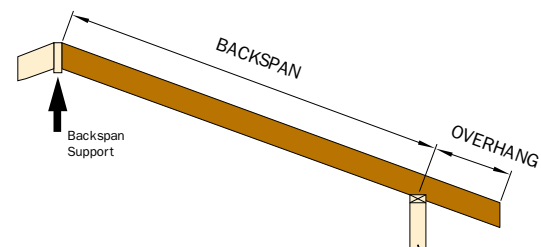
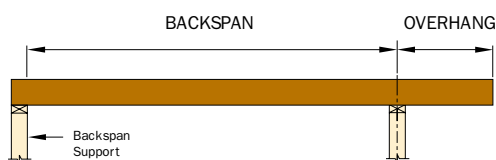
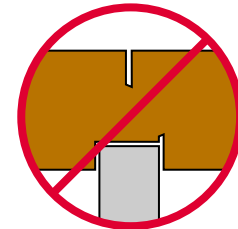

Beams with Overhangs



## SPACING

Tables, such as those for rafters, floor joists and ceiling joists require the spacing of members to be known or selected in order to obtain the required size for a given span. Spacing should be interpreted as the centre to centre distance between adjacent parallel members.

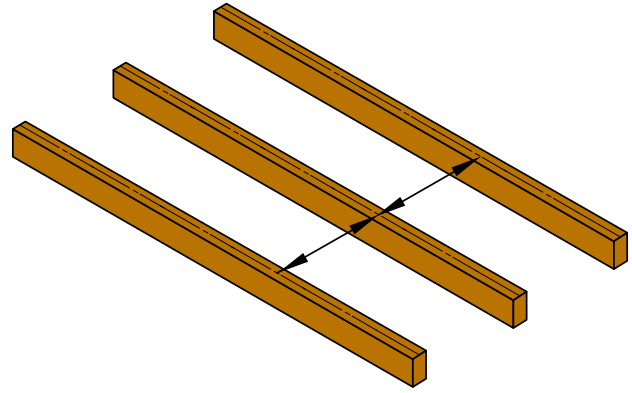

## LOAD WIDTH

Load width is used in these tables in order to determine the load applied to isolated beams such as lintels, bearers, hanging beams, strutting beams etc. Roof load width ‘RLW’, ceiling load width ‘CLW’ and floor load width ‘FLW’ are measures of the load applied from roofs, ceilings and floors respectively.

Roof load width (RLW) has a similar function to ‘Effective Length (EL)’ used in AS 1684 in order to determine wall framing sizes, including lintels.

Roof load width (RLW) can be related to ‘EL’ using the following formulae

$$RLW = \frac{EL}{2} + 0.6 \quad (\text{m}) \quad \text{or} \quad EL = 2 \times RLW - 1.2 \quad (\text{m})$$

Roof, floor and ceiling load width is used in these tables instead of ‘Effective Spacing (ES)’ as used in the previous edition because the terminology is more descriptive and is increasingly being used in other publications.

Examples showing the determination of roof load width, floor load width and ceiling load width are given as appropriate throughout this publication.

## LINTELS

Lintels are beams contained in walls required to support load over doors and windows. Their design includes stringent limitations on deflection required in order to maintain clearance to non-structural joinery items below.

Where doors or windows are not to be installed beneath a beam within a wall, or the door is a garage door for which larger deflections may be accommodated then tables such as those given for bressumers (beams over openings in walls), pitching beams, verandah beams and bearers as appropriate, will provide more realistic and more economical solutions.

## ROOF MASS

For most applications roof mass has been separated into four categories related to the type of roof cladding and whether or not a ceiling is included. The four categories together with the roof mass allowance for each case are given below. The roof masses quoted include for the usual types and thicknesses of claddings and ceiling linings and rafter or ceiling joist sizes and spacings. Self weight of members is allowed for separately.

ROOF TYPE	ROOF MASS ALLOWED
Sheet Roof	25 kg/m <sup>2</sup>
Sheet Roof and Ceiling	40 kg/m <sup>2</sup>
Tile Roof	75 kg/m <sup>2</sup>
Tile Roof and Ceiling	90 kg/m <sup>2</sup>

For the rafter and verandah beam tables designers need to determine the applicable roof mass. Guidance on the selection of roof mass can be obtained from the following table. The mass of typical timber framing arrangements are given in an Appendix on page 68.

APPROXIMATE MASS OF ROOF/CEILING MATERIALS				
Material				Mass kg/m <sup>2</sup>
<b>Roofing</b>	steel sheet 0.5 mm and battens			10
	steel sheet 0.55 mm and battens			15
	metal tiles and battens			15
	terracotta/concrete tiles and battens			60
<b>Ceiling</b>	t & g boards	pine	12 mm	6.5
		hwd	12 mm	9.0
		pine	19 mm	10.5
	plywood	pine	12 mm	7.0
			15 mm	9.0
	plasterboard		10 mm	7.5
			13 mm	13.0
		fibre cement sheet		4.7 mm
			6.3 mm	11.0
	<b>Insulation</b>	Lightweight plus sarking		

## YOUR GUARANTEE OF QUALITY

Hyspan is manufactured in a fully quality controlled process, independently third party audited by the Plywood Association of Australia (PAA).

Participation and compliance with the requirements of the PAA's process based quality control scheme, which includes product testing and monitoring of properties, is ultimately your best guarantee of quality. It also provides the basis for the PAA's Product Certification of Hyspan as conforming to the requirements of AS/NZS 4357 Structural Laminated Veneer Lumber. Conformance with AS/NZS 4357 ensures that Hyspan is "fit for purpose" for structural applications in accordance with AS 1720 Timber Structures Code.

The PAA's product certification scheme is accredited under the government Joint Accreditation system of Australia and New Zealand (JAS-ANZ) and as such is recognised as 'Evidence of Suitability' in the Building Code of Australia.

**In addition, Carter Holt Harvey, as manufacturer and member of the PAA quality control scheme undertake to replace any Hyspan found to have a defect in manufacture or to not conform with claimed performance criteria.**



### BRANDING OF HYSPAN

Hyspan is branded for your protection. Look alike substitution materials may not perform to the same high standards as Hyspan. For your own protection, look for the Hyspan brand and do not accept unauthorised substitutions. Instead, return any unauthorised substitution material to the supplier and call our enquiries number.

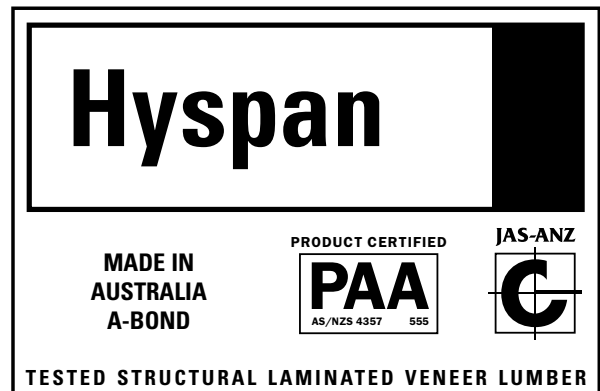

## STRUCTURAL CERTIFICATION



TIMBERBUILT  
Timber Structures Australia

12-12 HIDDLE WAY DONNINGTON 3176 AUSTRALIA  
TELEPHONE (061 21 2752 8827 FACSIMILE (061 21 2752 9727

### Structural Certification

As a professional engineer, qualified and experienced in timber engineering design I certify that the span table information contained in this brochure has been prepared in accordance with soundly based and widely recognised engineering principles.

In particular, design loadings for each application were obtained in accordance with AS 1170-1 and AS 1170-2 as appropriate.

Structural design has been performed in accordance with AS 1720-1. Serviceability and other design criteria used have been selected in accordance with guidelines contained in references 4 and 5 listed below and therefore generally correspond with those used in the preparation of the AS 1684 span tables.

Design properties used are those published by Carter Holt Harvey. Hyspan is Product Certified by the Plywood Association of Australia (PAA) as being manufactured and having properties determined in accordance with AS/NZS 4357. The PAA is accredited for product certification by the Joint Accreditation System of Australia and New Zealand (JAS-ANZ).

When installed in accordance with the specifications, details and limitations in this brochure, Hyspan will comply with the requirements of the Building Code of Australia.

#### References

1. AS 1170-1-1989 SAA Loading Code Part 1 Dead and Live Loads and Load Combinations.
2. AS 1170-2-1989 SAA Loading Code Part 2 Wind Loads.
3. AS 1720-1-1988 SAA Timber Structures Code Part 1 Design Methods.
4. AS/NZS 4357-1995 Structural Laminated Veneer Lumber
5. Low Rise Domestic and Similar Framed Structures Part 1 Design Criteria. CSIRO Division of Building Research - Special Report.
6. Timber Framed Housing - Design Methodology and Performance Criteria, C.E. MacKenzie & P.M. Junper, March 1997, National Association of Forest Industries.

B Hutchings,

B. Hutchings BE (Civil), MIE (Aust), CP Eng.  
NPER-3 Registered, Membership No. 8299  
Registered Building Practitioner, Victoria  
Registration No. EC-1573

9th October 1997

TIMBERBUILT PTY LTD A.C.N. 005 850 528

## TECHNICAL SUPPORT

For further information on Hyspan, guidance on the use of these tables or assistance with applications not included please contact Timberbuilt Pty Ltd. Timberbuilt provide technical services in support of Hyspan, Hybeam and other engineered timber products on behalf of Carter Holt Harvey.

Timberbuilt may be contacted on,

Free call 1800 808 131 Telephone (03) 9793 9997 Facsimile (03) 9793 9727

# BEARERS

## DETERMINATION OF FLOOR LOAD WIDTH

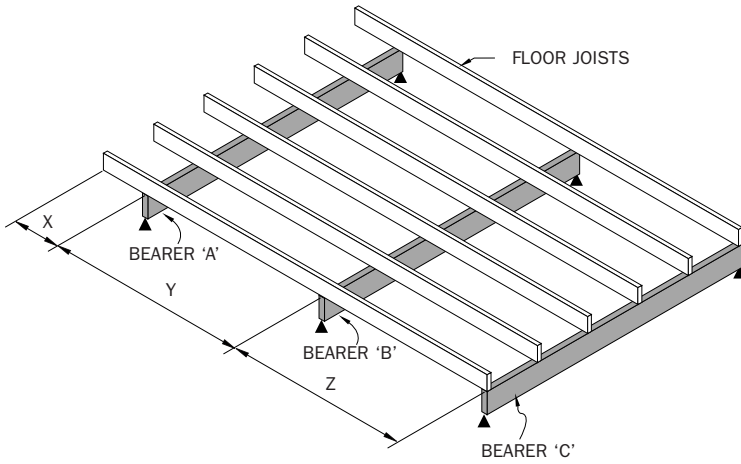

BEARER	FLOOR LOAD WIDTH 'FLW'
A	$FLW = X + \frac{Y}{2}$
B	$FLW = \frac{Y+Z}{2}$
C	$FLW = \frac{Z}{2}$

## DETERMINATION OF ROOF LOAD WIDTH

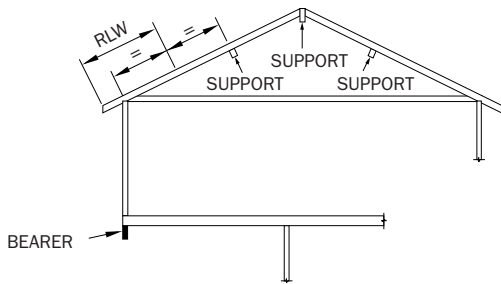

**CONVENTIONAL ROOF**  
COUPLED, STRUTTED RIDGE

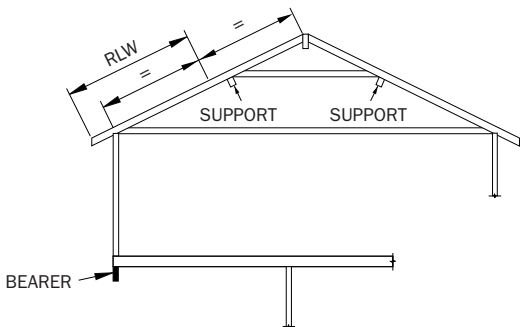

**CONVENTIONAL ROOF**  
COUPLED, UNSTRUTTED RIDGE

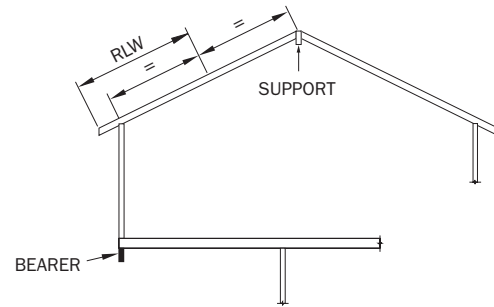

**CATHEDRAL ROOF**

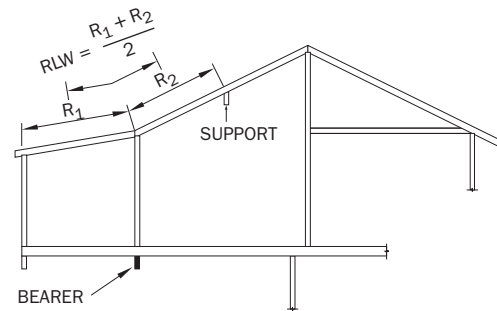

**CATHEDRAL ROOF**

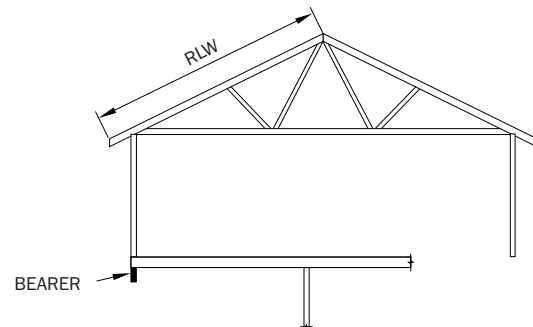

**TRUSSED ROOF**

The diagrams given above may also be used to determine roof load width for floor joists supporting load bearing walls and lintels in lower storey load bearing walls.



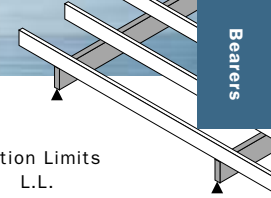

# BEARERS

*Supporting Floor Loads only*

Design Deflection Limits  
 D.L. L.L.  
 SPAN/300 SPAN/360  
 OR 12.5 mm OR 9 mm

HYSPAN SECTION D x B (mm)	FLOOR LOAD WIDTH 'FLW' (m)											
	1.2	1.5	1.8	2.1	2.4	2.7	3.0	3.6	4.2	4.8	5.4	6.0
	<b>MAXIMUM SINGLE SPAN (m)</b>											
95 x 63	1.9	1.8	1.7	1.6	1.5	1.5	1.4	1.3	1.3	1.2	1.2	1.1
130 x 63	2.6	2.4	2.3	2.2	2.1	2.0	1.9	1.8	1.7	1.6	1.6	1.5
150 x 63	3.0	2.8	2.6	2.5	2.4	2.3	2.2	2.1	2.0	1.9	1.8	1.8
150 x 75	3.1	2.9	2.8	2.6	2.5	2.4	2.3	2.2	2.1	2.0	1.9	1.9
170 x 63	3.4	3.1	3.0	2.8	2.7	2.6	2.5	2.4	2.2	2.1	2.1	2.0
200 x 63	3.8	3.6	3.5	3.3	3.2	3.0	2.9	2.8	2.6	2.5	2.4	2.3
240 x 63	4.4	4.1	4.0	3.8	3.7	3.6	3.5	3.3	3.2	3.0	2.9	2.8
300 x 63	5.2	4.9	4.7	4.5	4.4	4.2	4.1	3.9	3.8	3.7	3.6	3.5
300 x 75	5.4	5.1	4.9	4.7	4.5	4.4	4.3	4.1	4.0	3.8	3.7	3.6
360 x 63	5.9	5.6	5.4	5.2	5.0	4.8	4.7	4.5	4.3	4.2	4.1	4.0
400 x 63	6.4	6.1	5.8	5.6	5.4	5.2	5.1	4.9	4.7	4.5	4.4	4.3
400 x 75	6.7	6.3	6.1	5.8	5.6	5.5	5.3	5.1	4.9	4.7	4.6	4.5
450 x 63	7.0	6.6	6.3	6.1	5.9	5.7	5.6	5.3	5.1	5.0	4.8	4.7
525 x 75	8.1	7.7	7.4	7.2	6.9	6.7	6.5	6.3	6.0	5.8	5.6	5.5
	<b>MAXIMUM CONTINUOUS SPAN (m)</b>											
95 x 63	2.4	2.2	2.1	2.0	1.9	1.8	1.7	1.6	1.5	1.4	1.3	1.3
130 x 63	3.2	3.0	2.8	2.7	2.6	2.5	2.4	2.2	2.0	1.9	1.8	1.7
150 x 63	3.6	3.4	3.3	3.1	3.0	2.9	2.8	2.5	2.4	2.2	2.1	2.0
150 x 75	3.8	3.6	3.4	3.3	3.1	3.0	2.9	2.7	2.6	2.4	2.3	2.2
170 x 63	4.0	3.7	3.6	3.4	3.3	3.2	3.1	2.9	2.7	2.5	2.4	2.2
200 x 63	4.5	4.2	4.0	3.9	3.8	3.7	3.6	3.4	3.1	2.9	2.8	2.6
240 x 63	5.1	4.9	4.6	4.5	4.3	4.2	4.1	3.9	3.8	3.5	3.3	3.2
300 x 63	6.1	5.7	5.5	5.3	5.1	5.0	4.8	4.6	4.4	4.3	4.1	3.9
300 x 75	6.3	6.0	5.7	5.5	5.3	5.2	5.0	4.8	4.6	4.5	4.4	4.2
360 x 63	7.0	6.6	6.3	6.0	5.9	5.7	5.5	5.3	5.1	4.9	4.8	4.6
400 x 63	7.5	7.1	6.8	6.5	6.3	6.1	6.0	5.7	5.5	5.3	5.2	5.0
400 x 75	7.9	7.4	7.1	6.8	6.6	6.4	6.3	6.0	5.8	5.6	5.4	5.3
450 x 63	8.2	7.8	7.4	7.2	6.9	6.7	6.5	6.2	6.0	5.8	5.6	5.4
525 x 75	-	-	-	-	8.1	7.9	7.7	7.3	7.1	6.8	6.6	6.4

FOR DETERMINATION OF FLOOR LOAD WIDTH (FLW) FOR BEARERS - SEE PAGE 10.

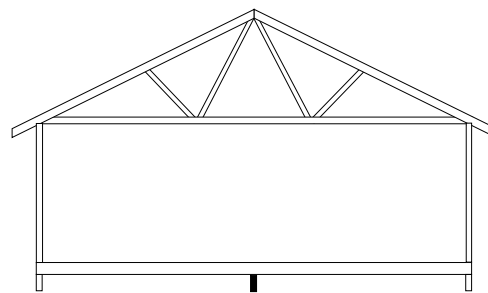

BEARER SUPPORTING FLOOR LOAD ONLY

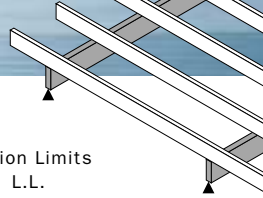

# BEARERS

Supporting Single or Upper Storey Load Bearing Walls

Design Deflection Limits  
 D.L. L.L.  
 SPAN/300 SPAN/360  
 OR 12.5 mm OR 9 mm

SHEET ROOF AND CEILING															
HYPAN SECTION D X B (mm)	FLOOR LOAD WIDTH 'FLW' (m)														
	1.2					2.1					3.0				
	ROOF LOAD WIDTH 'RLW' (m)														
	1.8	3.0	4.2	5.4	6.6	1.8	3.0	4.2	5.4	6.6	1.8	3.0	4.2	5.4	6.6
MAXIMUM SINGLE SPAN (m)															
95 x 63	1.4	1.3	1.3	1.2	1.2	1.2	1.2	1.2	1.1	1.1	1.2	1.1	1.1	1.1	1.0
130 x 63	1.9	1.8	1.7	1.6	1.6	1.7	1.6	1.6	1.5	1.5	1.6	1.5	1.5	1.5	1.4
150 x 63	2.2	2.1	2.0	1.9	1.8	2.0	1.9	1.8	1.8	1.7	1.8	1.8	1.7	1.7	1.6
150 x 75	2.3	2.2	2.1	2.0	1.9	2.1	2.0	1.9	1.9	1.8	1.9	1.9	1.8	1.8	1.7
170 x 63	2.5	2.3	2.2	2.1	2.1	2.2	2.1	2.1	2.0	1.9	2.1	2.0	2.0	1.9	1.9
200 x 63	2.9	2.7	2.6	2.5	2.4	2.6	2.5	2.4	2.4	2.3	2.4	2.4	2.3	2.2	2.2
240 x 63	3.5	3.3	3.1	3.0	2.9	3.1	3.0	2.9	2.8	2.7	2.9	2.8	2.8	2.7	2.6
300 x 63	4.2	4.0	3.9	3.8	3.7	3.9	3.8	3.6	3.5	3.4	3.7	3.5	3.4	3.4	3.3
300 x 75	4.3	4.2	4.0	3.9	3.8	4.0	3.9	3.8	3.7	3.6	3.8	3.7	3.6	3.5	3.5
360 x 63	4.8	4.6	4.4	4.3	4.2	4.4	4.3	4.2	4.1	4.0	4.2	4.1	4.0	3.9	3.9
400 x 63	5.1	5.0	4.8	4.7	4.6	4.8	4.7	4.5	4.4	4.3	4.6	4.4	4.4	4.3	4.2
400 x 75	5.4	5.2	5.0	4.9	4.7	5.0	4.9	4.7	4.6	4.5	4.7	4.6	4.5	4.5	4.4
450 x 63	5.6	5.4	5.2	5.1	5.0	5.2	5.1	5.0	4.8	4.7	5.0	4.9	4.8	4.7	4.6
525 x 75	6.5	6.3	6.1	6.0	5.8	6.1	5.9	5.8	5.7	5.5	5.8	5.7	5.6	5.5	5.4
MAXIMUM CONTINUOUS SPAN (m)															
95 x 63	1.7	1.6	1.5	1.5	1.4	1.5	1.5	1.4	1.4	1.3	1.4	1.4	1.4	1.3	1.3
130 x 63	2.3	2.2	2.1	2.0	2.0	2.1	2.0	2.0	1.9	1.8	2.0	1.9	1.8	1.8	1.8
150 x 63	2.7	2.5	2.4	2.3	2.3	2.4	2.3	2.3	2.2	2.1	2.3	2.2	2.1	2.1	2.0
150 x 75	2.8	2.7	2.6	2.5	2.4	2.6	2.5	2.4	2.3	2.3	2.4	2.3	2.3	2.2	2.1
170 x 63	3.0	2.9	2.8	2.7	2.6	2.7	2.6	2.6	2.5	2.4	2.6	2.5	2.4	2.4	2.3
200 x 63	3.6	3.4	3.2	3.1	3.0	3.2	3.1	3.0	2.9	2.8	3.0	2.9	2.8	2.8	2.7
240 x 63	4.1	4.0	3.9	3.7	3.6	3.8	3.7	3.6	3.5	3.4	3.6	3.5	3.4	3.3	3.2
300 x 63	4.9	4.7	4.5	4.4	4.3	4.5	4.4	4.3	4.2	4.1	4.3	4.2	4.1	4.0	4.0
300 x 75	5.1	4.9	4.7	4.6	4.5	4.7	4.6	4.5	4.4	4.3	4.5	4.4	4.3	4.2	4.1
360 x 63	5.6	5.4	5.2	5.1	4.9	5.2	5.0	4.9	4.8	4.7	4.9	4.8	4.7	4.6	4.5
400 x 63	6.0	5.8	5.6	5.5	5.3	5.6	5.5	5.3	5.2	5.1	5.3	5.2	5.0	4.9	4.8
400 x 75	6.3	6.1	5.9	5.7	5.6	5.8	5.7	5.5	5.4	5.3	5.6	5.4	5.3	5.2	5.1
450 x 63	6.6	6.3	6.1	6.0	5.8	6.1	6.0	5.8	5.7	5.6	5.7	5.5	5.4	5.3	5.2
525 x 75	7.7	7.4	7.2	7.0	6.8	7.1	7.0	6.8	6.6	6.5	6.8	6.7	6.5	6.4	6.3

FOR DETERMINATION OF FLOOR LOAD WIDTH AND ROOF LOAD WIDTH - SEE PAGE 10

Interpolation for intermediate values of 'RLW' and 'FLW' is permitted

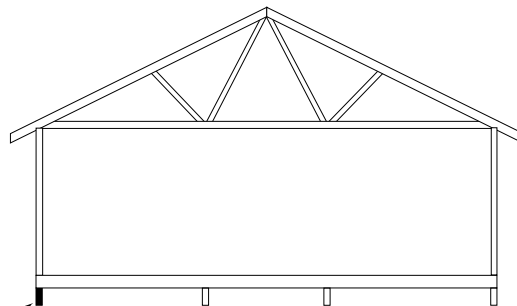

BEARER SUPPORTING SINGLE OR UPPER STOREY LOAD BEARING WALLS.

# BEARERS

Supporting Single or Upper Storey Load Bearing Walls

Design Deflection Limits  
 D.L. L.L.  
 SPAN/300 SPAN/360  
 OR 12.5 mm OR 9 mm

TILE ROOF AND CEILING															
HYSPAN SECTION D X B (mm)	FLOOR LOAD WIDTH 'FLW' (m)														
	1.2					2.1					3.0				
	ROOF LOAD WIDTH 'RLW' (m)														
	1.8	3.0	4.2	5.4	6.6	1.8	3.0	4.2	5.4	6.6	1.8	3.0	4.2	5.4	6.6
MAXIMUM SINGLE SPAN (m)															
95 x 63	1.3	1.2	1.1	1.0	1.0	1.2	1.1	1.0	1.0	0.9	1.1	1.1	1.0	0.9	0.9
130 x 63	1.7	1.6	1.5	1.4	1.3	1.6	1.5	1.4	1.3	1.3	1.5	1.4	1.4	1.3	1.2
150 x 63	2.0	1.8	1.7	1.6	1.5	1.8	1.7	1.6	1.5	1.5	1.7	1.6	1.6	1.5	1.4
150 x 75	2.1	1.9	1.8	1.7	1.6	1.9	1.8	1.7	1.6	1.6	1.8	1.7	1.7	1.6	1.5
170 x 63	2.2	2.1	1.9	1.8	1.7	2.1	1.9	1.8	1.8	1.7	2.0	1.9	1.8	1.7	1.6
200 x 63	2.6	2.4	2.3	2.2	2.1	2.4	2.3	2.2	2.1	2.0	2.3	2.2	2.1	2.0	1.9
240 x 63	3.2	2.9	2.7	2.6	2.5	2.9	2.7	2.6	2.5	2.4	2.8	2.6	2.5	2.4	2.3
300 x 63	3.9	3.6	3.4	3.2	3.1	3.7	3.4	3.2	3.1	3.0	3.5	3.3	3.1	3.0	2.9
300 x 75	4.1	3.8	3.6	3.4	3.3	3.8	3.6	3.4	3.3	3.1	3.7	3.5	3.3	3.2	3.0
360 x 63	4.5	4.2	4.0	3.8	3.7	4.2	4.0	3.8	3.7	3.5	4.0	3.9	3.7	3.6	3.4
400 x 63	4.8	4.5	4.3	4.2	4.0	4.6	4.3	4.2	4.0	3.9	4.4	4.2	4.0	3.9	3.8
400 x 75	5.0	4.7	4.5	4.3	4.2	4.7	4.5	4.3	4.2	4.1	4.6	4.4	4.2	4.1	4.0
450 x 63	5.3	5.0	4.7	4.5	4.4	5.0	4.7	4.5	4.4	4.2	4.8	4.6	4.4	4.3	4.2
525 x 75	6.1	5.8	5.5	5.3	5.1	5.8	5.5	5.3	5.1	5.0	5.6	5.3	5.2	5.0	4.9
MAXIMUM CONTINUOUS SPAN (m)															
95 x 63	1.6	1.4	1.3	1.3	1.2	1.4	1.3	1.3	1.2	1.2	1.4	1.3	1.2	1.2	1.1
130 x 63	2.1	2.0	1.8	1.7	1.7	2.0	1.8	1.7	1.7	1.6	1.9	1.8	1.7	1.6	1.5
150 x 63	2.5	2.3	2.1	2.0	1.9	2.3	2.1	2.0	1.9	1.8	2.1	2.0	1.9	1.8	1.8
150 x 75	2.6	2.4	2.2	2.1	2.0	2.4	2.2	2.1	2.0	1.9	2.3	2.1	2.0	2.0	1.9
170 x 63	2.8	2.6	2.4	2.3	2.2	2.6	2.4	2.3	2.2	2.1	2.4	2.3	2.2	2.1	2.0
200 x 63	3.3	3.0	2.8	2.7	2.5	3.0	2.8	2.7	2.5	2.4	2.9	2.7	2.6	2.5	2.4
240 x 63	3.9	3.6	3.4	3.2	3.0	3.6	3.4	3.2	3.1	2.9	3.4	3.2	3.1	2.9	2.8
300 x 63	4.6	4.3	4.1	3.9	3.8	4.3	4.1	3.9	3.8	3.7	4.1	4.0	3.8	3.7	3.5
300 x 75	4.8	4.5	4.3	4.1	4.0	4.5	4.3	4.1	4.0	3.8	4.3	4.1	4.0	3.9	3.8
360 x 63	5.2	4.9	4.7	4.5	4.3	4.9	4.7	4.5	4.3	4.2	4.7	4.5	4.3	4.1	4.0
400 x 63	5.7	5.3	5.1	4.9	4.6	5.3	5.1	4.9	4.7	4.5	5.1	4.8	4.6	4.4	4.3
400 x 75	5.9	5.5	5.3	5.1	4.9	5.6	5.3	5.1	4.9	4.8	5.3	5.1	4.9	4.8	4.7
450 x 63	6.2	5.8	5.5	5.2	4.9	5.8	5.5	5.3	5.0	4.8	5.4	5.2	4.9	4.7	4.6
525 x 75	7.2	6.8	6.5	6.2	6.0	6.8	6.5	6.2	6.0	5.8	6.5	6.3	6.0	5.9	5.7

FOR DETERMINATION OF FLOOR LOAD WIDTH AND ROOF LOAD WIDTH - SEE PAGE 10

Interpolation for intermediate values of 'RLW' and 'FLW' is permitted

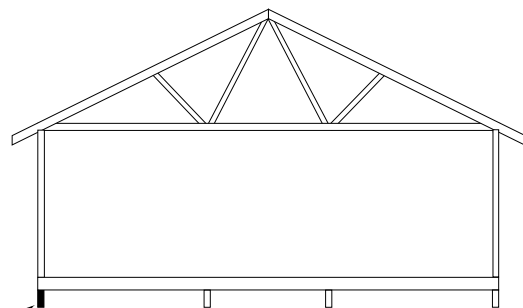

BEARER SUPPORTING SINGLE OR UPPER STOREY LOAD BEARING WALLS.

**BEARERS***Supporting Two Storey Load Bearing Walls*

Design Deflection Limits  
 D.L. L.L.  
 SPAN/300 SPAN/360  
 OR 12.5 mm OR 9 mm

SHEET ROOF AND CEILING												
HYSPAN SECTION D X B (mm)	GROUND FLOOR LOAD WIDTH 'FLW' (m)											
	1.5						3.0					
	FIRST FLOOR LOAD WIDTH 'FLW' (m)											
	1.5			3.0			1.5			3.0		
	ROOF LOAD WIDTH 'RLW' (m)											
2.4	4.5	6.6	2.4	4.5	6.6	2.4	4.5	6.6	2.4	4.5	6.6	
MAXIMUM SINGLE SPAN (m)												
95 x 63	1.1	1.1	1.0	1.0	1.0	1.0	1.1	1.0	1.0	1.0	1.0	0.9
2/95 x 45	1.3	1.2	1.2	1.2	1.1	1.1	1.2	1.1	1.1	1.1	1.1	1.0
130 x 63	1.5	1.5	1.4	1.4	1.4	1.3	1.4	1.4	1.3	1.3	1.3	1.3
2/130 x 45	1.7	1.7	1.6	1.6	1.5	1.5	1.6	1.6	1.5	1.5	1.5	1.4
150 x 63	1.8	1.7	1.6	1.6	1.6	1.5	1.7	1.6	1.5	1.6	1.5	1.5
150 x 75	1.9	1.8	1.7	1.7	1.7	1.6	1.8	1.7	1.6	1.6	1.6	1.5
2/150 x 45	2.0	1.9	1.8	1.8	1.8	1.7	1.9	1.8	1.7	1.7	1.7	1.6
170 x 63	2.0	1.9	1.8	1.9	1.8	1.7	1.9	1.8	1.7	1.8	1.7	1.6
2/170 x 45	2.3	2.2	2.1	2.1	2.0	1.9	2.1	2.0	2.0	2.0	1.9	1.9
200 x 63	2.4	2.3	2.2	2.2	2.1	2.0	2.2	2.1	2.0	2.1	2.0	1.9
2/200 x 45	2.7	2.5	2.4	2.5	2.4	2.3	2.5	2.4	2.3	2.3	2.2	2.2
240 x 63	2.8	2.7	2.6	2.6	2.5	2.4	2.7	2.5	2.5	2.5	2.4	2.3
2/240 x 45	3.2	3.0	2.9	2.9	2.8	2.7	3.0	2.9	2.8	2.8	2.7	2.6
300 x 63	3.5	3.4	3.2	3.3	3.1	3.0	3.3	3.2	3.1	3.1	3.0	2.9
300 x 75	3.7	3.6	3.4	3.5	3.3	3.2	3.5	3.4	3.3	3.3	3.2	3.1
MAXIMUM CONTINUOUS SPAN (m)												
95 x 63	1.4	1.3	1.3	1.3	1.2	1.2	1.3	1.2	1.2	1.2	1.2	1.1
2/95 x 45	1.6	1.5	1.4	1.4	1.4	1.3	1.5	1.4	1.4	1.4	1.3	1.3
130 x 63	1.9	1.8	1.7	1.8	1.7	1.6	1.8	1.7	1.6	1.6	1.6	1.5
2/130 x 45	2.1	2.0	2.0	2.0	1.9	1.8	2.0	1.9	1.9	1.9	1.8	1.8
150 x 63	2.2	2.1	2.0	2.0	1.9	1.9	2.1	2.0	1.9	1.9	1.8	1.8
150 x 75	2.3	2.2	2.1	2.1	2.1	2.0	2.2	2.1	2.0	2.0	2.0	1.9
2/150 x 45	2.5	2.4	2.3	2.3	2.2	2.1	2.3	2.2	2.1	2.2	2.1	2.0
170 x 63	2.5	2.4	2.3	2.3	2.2	2.1	2.3	2.2	2.2	2.1	2.1	2.0
2/170 x 45	2.8	2.7	2.6	2.6	2.5	2.4	2.6	2.5	2.4	2.4	2.4	2.3
200 x 63	2.9	2.8	2.7	2.7	2.6	2.5	2.7	2.6	2.5	2.5	2.4	2.4
2/200 x 45	3.3	3.1	3.0	3.0	2.9	2.8	3.1	3.0	2.8	2.9	2.8	2.7
240 x 63	3.5	3.3	3.2	3.2	3.1	3.0	3.3	3.1	3.0	3.0	2.9	2.8
2/240 x 45	3.9	3.8	3.6	3.5	3.4	3.3	3.6	3.4	3.3	3.3	3.2	3.1
300 x 63	4.2	4.1	3.9	3.9	3.8	3.7	4.0	3.8	3.7	3.7	3.6	3.5
300 x 75	4.4	4.2	4.1	4.1	4.0	3.9	4.2	4.1	3.9	4.0	3.9	3.8

FOR DETERMINATION OF FLOOR LOAD WIDTHS AND ROOF LOAD WIDTH - SEE PAGE 10

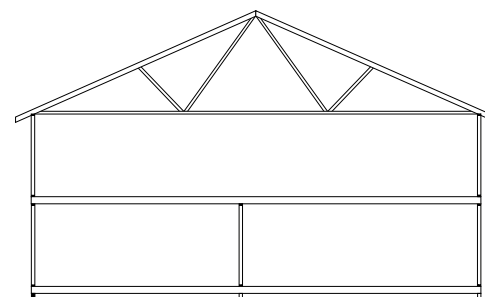

BEARER SUPPORTING TWO STOREY LOAD BEARING WALL



# BEARERS

Supporting Two Storey Load Bearing Walls

Design Deflection Limits  
 D.L. L.L.  
 SPAN/300 SPAN/360  
 OR 12.5 mm OR 9 mm

TILE ROOF AND CEILING												
HYSPAN SECTION D X B (mm)	GROUND FLOOR LOAD WIDTH 'FLW' (m)											
	1.5						3.0					
	FIRST FLOOR LOAD WIDTH 'FLW' (m)											
	1.5			3.0			1.5			3.0		
	ROOF LOAD WIDTH 'RLW' (m)											
2.4	4.5	6.6	2.4	4.5	6.6	2.4	4.5	6.6	2.4	4.5	6.6	
MAXIMUM SINGLE SPAN (m)												
95 x 63	1.1	1.0	0.9	1.0	0.9	0.9	1.0	0.9	0.9	0.9	0.9	0.8
2/95 x 45	1.2	1.1	1.0	1.1	1.0	1.0	1.1	1.0	1.0	1.1	1.0	0.9
130 x 63	1.4	1.3	1.2	1.3	1.3	1.2	1.4	1.3	1.2	1.3	1.2	1.1
2/130 x 45	1.6	1.5	1.4	1.5	1.4	1.3	1.5	1.4	1.3	1.4	1.4	1.3
150 x 63	1.7	1.5	1.4	1.6	1.4	1.4	1.6	1.5	1.4	1.5	1.4	1.3
150 x 75	1.8	1.6	1.5	1.6	1.5	1.4	1.7	1.5	1.5	1.6	1.5	1.4
2/150 x 45	1.9	1.7	1.6	1.7	1.6	1.5	1.8	1.6	1.5	1.7	1.6	1.5
170 x 63	1.9	1.7	1.6	1.8	1.6	1.5	1.8	1.7	1.6	1.7	1.6	1.5
2/170 x 45	2.1	1.9	1.8	2.0	1.8	1.7	2.0	1.9	1.8	1.9	1.8	1.7
200 x 63	2.2	2.0	1.9	2.1	1.9	1.8	2.1	1.9	1.8	2.0	1.9	1.8
2/200 x 45	2.5	2.3	2.1	2.3	2.2	2.0	2.4	2.2	2.1	2.2	2.1	2.0
240 x 63	2.7	2.4	2.3	2.5	2.3	2.2	2.5	2.3	2.2	2.4	2.2	2.1
2/240 x 45	3.0	2.7	2.6	2.8	2.6	2.5	2.8	2.6	2.5	2.7	2.5	2.4
300 x 63	3.3	3.0	2.8	3.1	2.9	2.7	3.1	2.9	2.7	3.0	2.8	2.6
300 x 75	3.5	3.2	3.0	3.3	3.1	2.9	3.3	3.1	2.9	3.1	2.9	2.8
MAXIMUM CONTINUOUS SPAN (m)												
95 x 63	1.3	1.2	1.1	1.2	1.1	1.0	1.2	1.1	1.0	1.1	1.0	0.9
2/95 x 45	1.5	1.3	1.3	1.4	1.3	1.2	1.4	1.3	1.2	1.3	1.2	1.2
130 x 63	1.8	1.6	1.5	1.7	1.5	1.4	1.7	1.6	1.4	1.6	1.4	1.2
2/130 x 45	2.0	1.8	1.7	1.9	1.7	1.6	1.9	1.8	1.7	1.8	1.7	1.6
150 x 63	2.1	1.9	1.8	1.9	1.8	1.6	1.9	1.8	1.6	1.8	1.6	1.4
150 x 75	2.2	2.0	1.9	2.0	1.9	1.8	2.1	1.9	1.8	1.9	1.8	1.7
2/150 x 45	2.3	2.1	2.0	2.2	2.0	1.9	2.2	2.0	1.9	2.1	1.9	1.8
170 x 63	2.3	2.1	2.0	2.2	2.0	1.8	2.2	2.0	1.8	2.0	1.8	1.6
2/170 x 45	2.6	2.4	2.2	2.4	2.3	2.1	2.5	2.3	2.2	2.3	2.2	2.1
200 x 63	2.7	2.5	2.3	2.6	2.4	2.1	2.6	2.4	2.1	2.4	2.1	1.9
2/200 x 45	3.1	2.8	2.6	2.9	2.7	2.5	2.9	2.7	2.5	2.7	2.6	2.4
240 x 63	3.3	3.0	2.8	3.1	2.9	2.5	3.1	2.9	2.6	2.9	2.6	2.3
2/240 x 45	3.7	3.4	3.2	3.4	3.1	3.0	3.4	3.2	3.0	3.2	3.0	2.9
300 x 63	4.0	3.8	3.5	3.7	3.5	3.1	3.8	3.5	3.2	3.5	3.2	2.9
300 x 75	4.2	3.9	3.7	4.0	3.8	3.6	4.0	3.8	3.6	3.8	3.6	3.4

FOR DETERMINATION OF FLOOR LOAD WIDTHS AND ROOF LOAD WIDTH - SEE PAGE 10

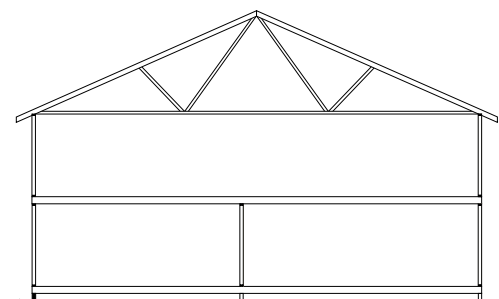

BEARER SUPPORTING TWO STOREY LOAD BEARING WALL

# BEARERS FOR POLE FRAME CONSTRUCTION

*Supporting Floor Loads only*

## FLOOR LOAD WIDTH FOR BEARERS IN POLE FRAME CONSTRUCTION

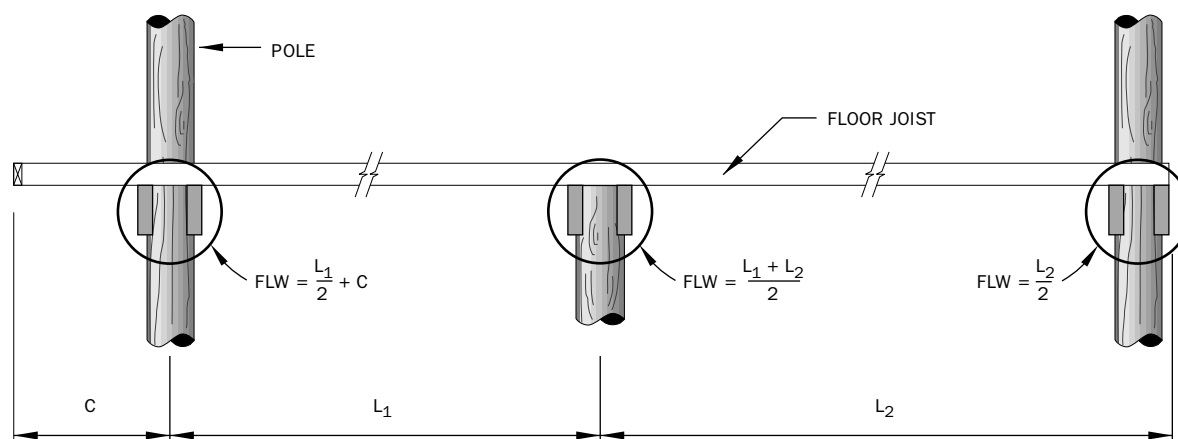

## BEARING AT SUPPORTS

It is important that adequate bearing support is provided. It should not be assumed that merely bolting to the sides of poles will provide adequate support. Usually it will be necessary to provide a seat for bearing either by notching the pole or using a steel angle as shown below.

The minimum bearing areas required have been coded A to E in the Span Table and the corresponding minimum bearing areas for each code specified in the adjacent Bearing Support Table.

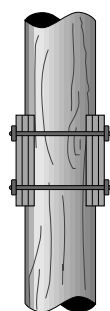

**NOTCHED SEAT**

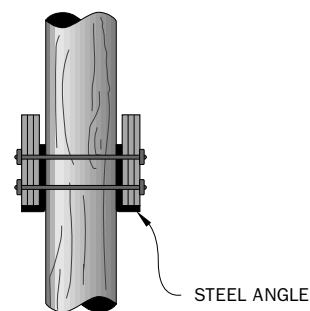

**STEEL ANGLE SEAT**

### Notes:

1. In calculating the bearing area for a notched seat do not include any untreated Lyctus susceptible sapwood.
2. Bolts may be designed to partially or fully support the load.
3. It is recommended that an engineer is engaged to design these connections.

# BEARERS FOR POLE FRAME CONSTRUCTION

Supporting Floor Loads only

Design Deflection Limits  
D.L. L.L.  
SPAN/300 SPAN/360  
OR 12.5 mm OR 9 mm

HYSpan SECTION D X B (mm)	FLOOR LOAD WIDTH 'FLW' (m)											
	1.2	1.5	1.8	2.1	2.4	2.7	3.0	3.6	4.2	4.8	5.4	6.0
	<b>MAXIMUM SINGLE SPAN (m)</b>											
2/130 x 45	3.0 A	2.7 A	2.6 B	2.5 B	2.3 B	2.3 B	2.2 B	2.0 B	1.9 B	1.9 B	1.8 B	1.7 B
2/150 x 45	3.4 B	3.2 B	3.0 B	2.8 B	2.7 B	2.6 B	2.5 B	2.4 B	2.2 B	2.1 B	2.1 B	2.0 C
2/170 x 45	3.7 B	3.5 B	3.3 B	3.2 B	3.0 B	2.9 B	2.8 B	2.7 B	2.5 B	2.4 C	2.3 C	2.2 C
2/200 x 45	4.2 B	4.0 B	3.8 B	3.6 B	3.5 B	3.4 B	3.3 B	3.2 C	3.0 C	2.9 C	2.8 C	2.6 C
2/240 x 45	4.8 B	4.5 B	4.3 B	4.2 B	4.0 B	3.9 B	3.8 C	3.6 C	3.5 C	3.4 C	3.3 C	3.1 C
2/300 x 45	5.7 B	5.4 B	5.1 B	4.9 B	4.8 C	4.6 C	4.5 C	4.3 C	4.1 C	4.0 D	3.9 D	3.8 D
2/400 x 45	7.0 B	6.6 C	6.3 C	6.1 C	5.9 C	5.7 C	5.6 C	5.3 D	5.1 D	5.0 D	4.8 D	4.7 D
	<b>MAXIMUM CONTINUOUS SPAN (m)</b>											
2/130 x 45	3.5 B	3.4 B	3.2 B	3.0 B	2.9 B	2.8 B	2.7 B	2.5 B	2.4 C	2.3 C	2.0 C	1.8 C
2/150 x 45	3.9 B	3.7 B	3.6 B	3.4 B	3.3 B	3.2 B	3.1 C	2.9 C	2.8 C	2.6 C	2.3 C	2.1 C
2/170 x 45	4.3 B	4.1 B	3.9 B	3.8 B	3.6 B	3.5 B	3.4 C	3.3 C	3.1 C	3.0 C	2.6 C	2.4 C
2/200 x 45	4.9 B	4.6 B	4.4 B	4.3 C	4.1 C	4.0 C	3.9 C	3.7 C	3.6 D	3.5 D	3.1 D	2.8 D
2/240 x 45	5.6 B	5.3 B	5.1 C	4.9 C	4.7 C	4.6 C	4.5 C	4.3 D	4.1 D	4.0 D	3.7 D	3.3 D
2/300 x 45	6.6 C	6.3 C	6.0 C	5.8 C	5.6 D	5.4 D	5.3 D	5.0 D	4.9 D	4.7 D	4.6 E	4.2 E
2/400 x 45	8.2 C	7.8 C	7.4 C	7.2 D	6.9 D	6.7 D	6.5 D	6.3 D	6.0 E	5.7 E	5.5 E	5.3 E

The above table specifies Hyspan bearers used in pairs for pole frame construction. Where single sections are to be used refer to table 1.

BEARING AT SUPPORTS		
CODE	END SUPPORT <sup>2</sup>	INTERNAL SUPPORT <sup>3</sup>
	REQUIRED BEARING AREA <sup>1</sup> (mm <sup>2</sup> )	
A	500	N/A
B	1200	2500
C	2000	4000
D	3250	6500
E	4500	9000

1. Bearing areas quoted apply for each individual Hyspan section.
2. End support values apply where the end of the bearer is within 300mm of the support.
3. Internal support areas apply for continuous span bearers only.

## BEARERS FOR POLE FRAME CONSTRUCTION

*Supporting Single or Upper Storey Load Bearing Walls*

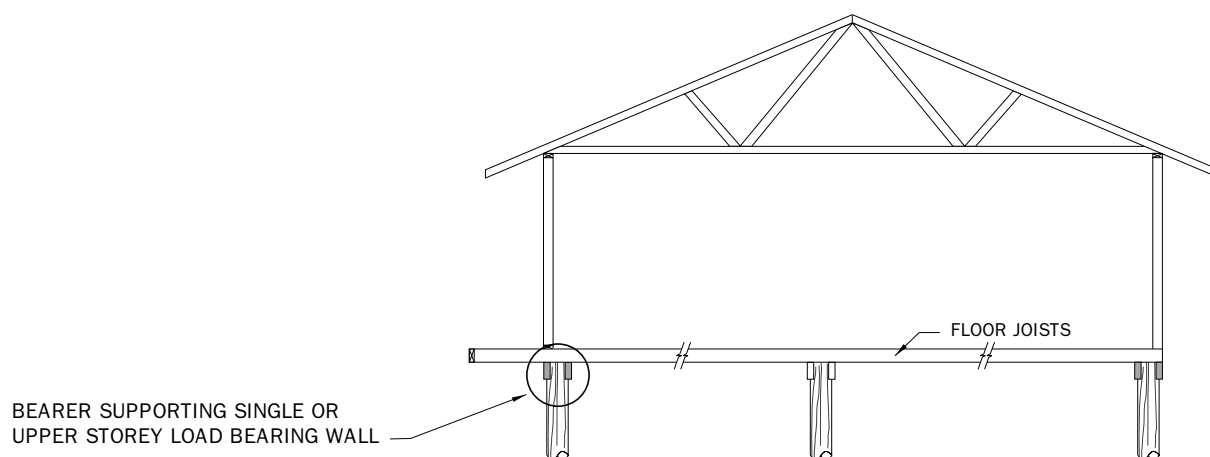

### BEARING AT SUPPORTS

It is important that adequate bearing support is provided. It should not be assumed that merely bolting to the sides of poles will provide adequate support. Usually it will be necessary to provide a seat for bearing either by notching the pole or using a steel angle as shown below.

The minimum bearing areas required have been coded A to D in the Span Table and the corresponding minimum bearing areas for each code specified in the adjacent Bearing Support Table.

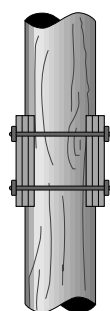

**NOTCHED SEAT**

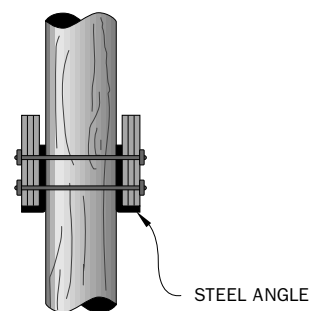

**STEEL ANGLE SEAT**

#### Notes:

1. In calculating the bearing area for a notched seat do not include any untreated Lyctus susceptible sapwood.
2. Bolts may be designed to partially or fully support the load.
3. It is recommended that an engineer is engaged to design these connections.



# BEARERS FOR POLE FRAME CONSTRUCTION

Supporting Single or Upper Storey Load Bearing Walls

Design Deflection Limits  
D.L. L.L.  
SPAN/300 SPAN/360  
OR 12.5 mm OR 9 mm

SHEET ROOF AND CEILING															
HYSpan SECTION D X B (mm)	FLOOR LOAD WIDTH 'FLW' (m)														
	1.2					2.1					3.0				
	ROOF LOAD WIDTH 'RLW' (m)														
	1.8	3.0	4.2	5.4	6.6	1.8	3.0	4.2	5.4	6.6	1.8	3.0	4.2	5.4	6.6
MAXIMUM SINGLE SPAN (m)															
2/130 x 45	2.1 A	2.0 A	1.9 A	1.9 A	1.8 A	1.9 A	1.8 B	1.8 B	1.7 B	1.7 B	1.8 B	1.7 B	1.7 B	1.6 B	1.6 B
2/150 x 45	2.4 A	2.3 A	2.2 A	2.1 A	2.1 B	2.2 B	2.1 B	2.1 B	2.0 B	1.9 B	2.1 B	2.0 B	1.9 B	1.9 B	1.8 B
2/170 x 45	2.8 A	2.6 A	2.5 B	2.4 B	2.3 B	2.5 B	2.4 B	2.3 B	2.3 B	2.2 B	2.3 B	2.3 B	2.2 B	2.1 B	2.1 B
2/200 x 45	3.2 B	3.1 B	2.9 B	2.8 B	2.7 B	2.9 B	2.8 B	2.7 B	2.6 B	2.6 B	2.7 B	2.7 B	2.6 B	2.5 B	2.5 B
2/240 x 45	3.8 B	3.7 B	3.5 B	3.4 B	3.3 B	3.5 B	3.4 B	3.3 B	3.2 B	3.1 B	3.3 B	3.2 B	3.1 B	3.0 B	3.0 C
2/300 x 45	4.5 B	4.4 B	4.2 B	4.1 B	4.0 B	4.2 B	4.1 B	4.0 B	3.9 C	3.8 C	4.0 C	3.9 C	3.8 C	3.8 C	3.7 C
2/400 x 45	5.6 B	5.4 B	5.2 B	5.1 B	5.0 C	5.2 C	5.1 C	4.9 C	4.8 C	4.7 C	5.0 C	4.8 C	4.7 C	4.7 C	4.6 C
MAXIMUM CONTINUOUS SPAN (m)															
2/130 x 45	2.8 B	2.7 B	2.6 B	2.5 B	2.4 B	2.6 B	2.5 B	2.4 B	2.3 B	2.3 B	2.4 B	2.3 B	2.3 B	2.2 B	2.1 B
2/150 x 45	3.3 B	3.1 B	3.0 B	2.9 B	2.8 B	3.0 B	2.8 B	2.8 B	2.7 B	2.6 B	2.8 B	2.7 B	2.6 B	2.5 B	2.5 B
2/170 x 45	3.7 B	3.5 B	3.4 B	3.2 B	3.1 B	3.3 B	3.2 B	3.1 B	3.0 B	2.9 B	3.1 B	3.0 B	2.9 B	2.9 C	2.8 C
2/200 x 45	3.9 B	3.8 B	3.7 B	3.6 B	3.6 B	3.7 B	3.6 B	3.7 B	3.6 C	3.5 C	3.5 C	3.4 C	3.3 C	3.3 C	3.2 C
2/240 x 45	4.5 B	4.3 B	4.2 B	4.1 B	4.0 B	4.2 B	4.1 C	4.0 C	3.9 C	3.8 C	4.0 C	3.9 C	3.8 C	3.7 C	3.6 C
2/300 x 45	5.3 B	5.1 B	5.0 B	4.8 C	4.7 C	4.9 C	4.8 C	4.7 C	4.6 C	4.4 C	4.5 D	4.4 C	4.3 C	4.2 C	4.1 C
2/400 x 45	6.2 C	6.0 C	5.8 C	5.6 C	5.4 C	5.5 C	5.4 C	5.2 C	5.1 C	5.0 C	5.1 C	5.0 D	4.9 D	4.8 D	4.7 D

FOR DETERMINATION OF ROOF LOAD WIDTH AND FLOOR LOAD WIDTH - SEE PAGES 10 AND 16 RESPECTIVELY

The above table specifies Hyspan bearers used in pairs for pole frame construction. Where single sections are to be used refer to table 2.

BEARING AT SUPPORTS		
CODE	END SUPPORT <sup>2</sup>	INTERNAL SUPPORT <sup>3</sup>
	REQUIRED BEARING AREA <sup>1</sup> (mm <sup>2</sup> )	
A	500	N/A
B	1200	2500
C	2000	4000
D	3250	6500

1. Bearing areas quoted apply for each individual Hyspan section.

2. End support values apply where the end of the bearer is within 300mm of the support.

3. Internal support areas apply for continuous span bearers only.

# FLOOR JOISTS

## BLOCKING OR LATERAL SUPPORT REQUIREMENTS

1. For joists with  $D/B > 4$  provide intermittent blocking at supports as shown below. During construction provide a temporary batten connecting the top of the blocked joists to the other joists to prevent them rolling prior to flooring being fixed.

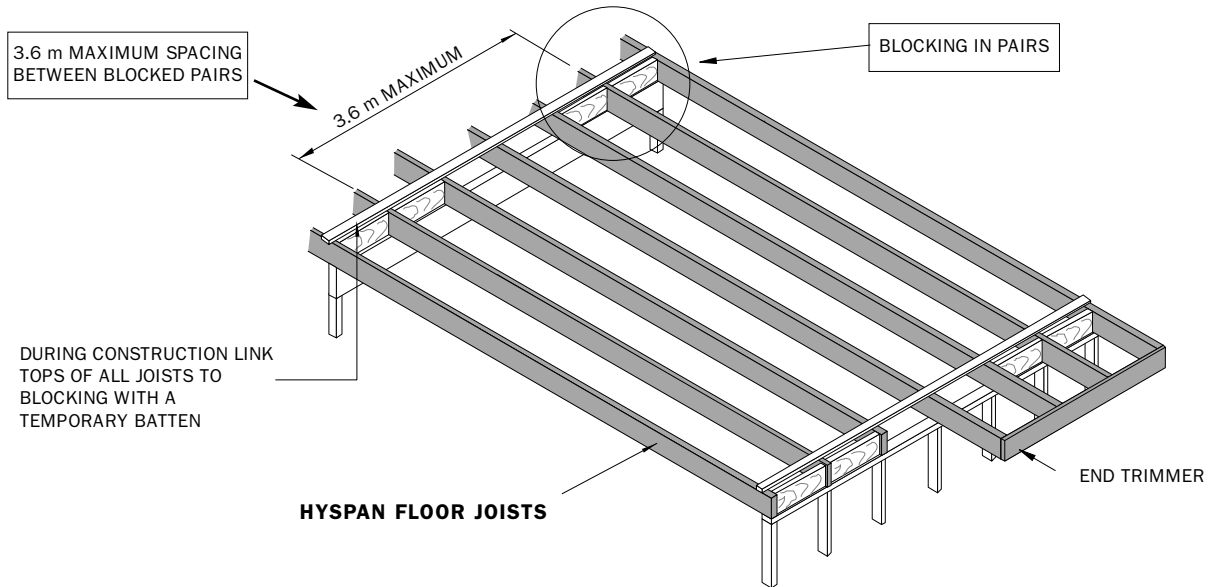

2. For joists marked with an \* also provide mid-span blocking and a temporary batten as shown below in order to prevent twisting or rollover during construction.

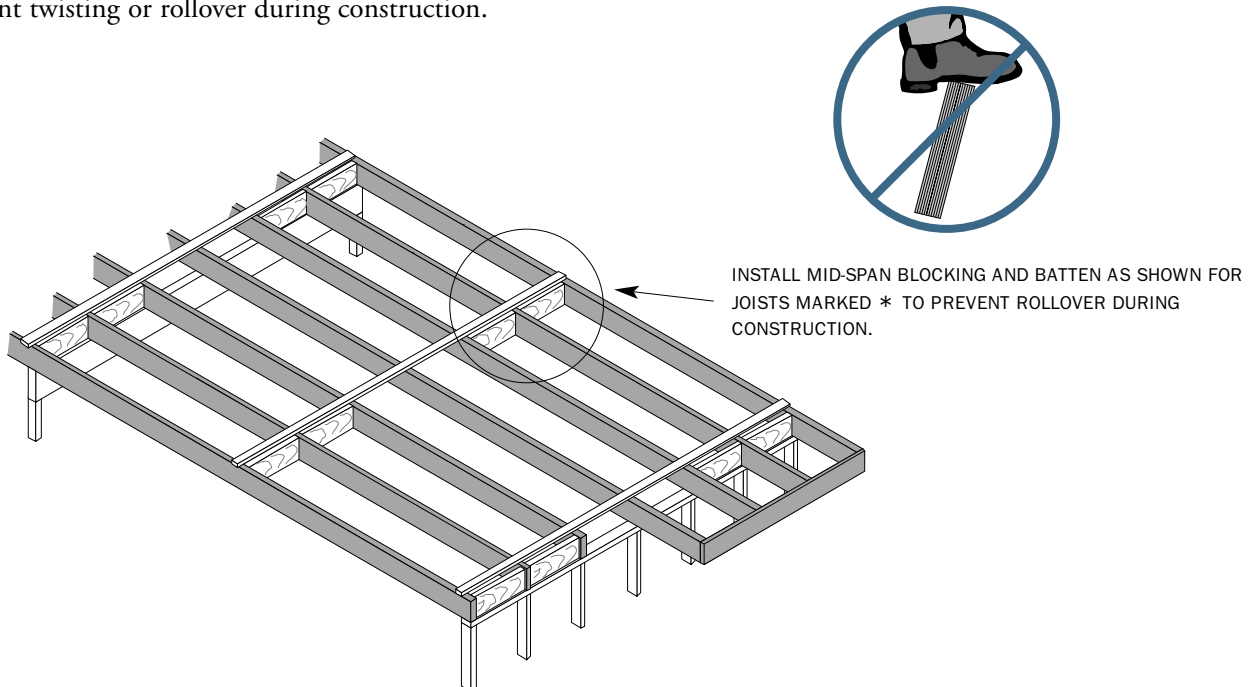

NOTE: The above blocking and lateral support details are minimum requirements. Use of alternative blocking details given in AS 1684 are also acceptable.

# FLOOR JOISTS

Supporting Floor Loads only

Design Deflection Limits

D.L.

SPAN/300

OR 12.5 mm

L.L.

SPAN/360

OR 9 mm

Dynamic Criteria

2 mm/1kN

HYSPAN SECTION D X B (mm)	FLOOR JOIST SPACINGS (mm)									
	300		400		450		480		600	
	MAXIMUM SINGLE SPAN AND OVERHANG 'O/H' (m)									
	SPAN	O/H	SPAN	O/H	SPAN	O/H	SPAN	O/H	SPAN	O/H
95 x 36	2.1	0.5	1.8	0.4	1.7	0.4	1.7	0.4	1.7	0.3
95 x 45	2.3	0.6	1.9	0.5	1.9	0.5	1.9	0.4	1.8	0.4
130 x 36	3.4	0.8	2.6	0.7	2.4	0.7	2.5	0.6	2.3	0.6
130 x 45	3.6	0.9	2.8	0.8	2.7	0.8	2.7	0.7	2.5	0.7
150 x 36	3.8	0.9	3.0	0.9	2.9	0.9	2.9	0.8	2.7	0.7
150 x 45	4.0	1.0	3.3	1.0	3.1	0.9	3.2	0.9	3.0	0.8
170 x 36	4.2	1.1	3.5	1.0	3.3	1.0	3.4	0.9	3.1	0.9
170 x 45	4.4	1.2	3.8	1.1	3.6	1.0	3.7	1.0	3.4	0.9
200 x 36*	4.7	1.3	4.3	1.2	4.0	1.1	4.2	1.1	3.8	1.0
200 x 45	5.0	1.4	4.6	1.2	4.4	1.2	4.4	1.2	4.1	1.1
240 x 36*	5.4	1.5	5.0	1.4	4.9	1.3	4.8	1.3	4.5	1.2
240 x 45	5.7	1.7	5.3	1.5	5.1	1.5	5.1	1.4	4.8	1.3
300 x 45*	6.7	2.1	6.3	1.9	6.1	1.8	6.0	1.8	5.7	1.7
400 x 45*	8.1	2.6	7.7	2.5	7.5	2.4	7.4	2.4	7.0	2.2
	MAXIMUM CONTINUOUS SPAN AND OVERHANG 'O/H' (m)									
95 x 36	2.8	0.4	2.1	0.4	2.0	0.4	2.0	0.3	1.9	0.3
95 x 45	3.1	0.5	2.3	0.4	2.2	0.4	2.2	0.4	2.1	0.3
130 x 36	3.9	0.7	3.1	0.7	2.9	0.6	2.8	0.6	2.7	0.5
130 x 45	4.2	0.8	3.4	0.7	3.2	0.7	3.1	0.7	3.0	0.5
150 x 36	4.4	0.9	3.8	0.8	3.4	0.8	3.3	0.8	3.2	0.7
150 x 45	4.7	1.0	4.2	0.9	3.8	0.9	3.6	0.8	3.5	0.7
170 x 36*	4.9	1.0	4.5	0.9	4.0	0.9	3.9	0.9	3.7	0.8
170 x 45	5.2	1.1	4.8	1.0	4.4	0.9	4.2	1.0	4.0	0.9
200 x 36*	5.5	1.2	5.1	1.1	4.9	1.0	4.7	1.0	4.5	0.9
200 x 45	5.8	1.3	5.4	1.2	5.3	1.1	5.1	1.1	4.9	1.0
240 x 36*	6.3	1.5	5.9	1.3	5.7	1.3	5.6	1.2	5.3	1.1
240 x 45*	6.7	1.6	6.2	1.4	6.0	1.4	5.9	1.3	5.6	1.2
300 x 45*	7.8	2.0	7.3	1.8	7.1	1.7	7.0	1.7	6.6	1.6

## SUB FLOOR APPLICATIONS

Under normal conditions where adequate ventilation and clearance are provided Hyspan may be safely used for sub-floor applications without the likelihood of decay.

## DECKS AND BALCONIES

Overhanging floor joists or floor joist used for decks or balconies must either be totally protected from wetting or preservative treated to H3 level and painted.

## FLOOR RIGIDITY

The span tables above have been prepared taking dynamic performance into account. The maximum joist spans given have been determined assuming particleboard flooring is used. The spans are therefore conservative for the normal thicknesses of plywood and t & g board flooring.

The dynamic design has been performed using procedures detailed in a draft industry standard: 'Timber Framed Housing - Design Methodology and Performance Criteria' C E MacKenzie and P M Juniper, March 1997.

The shaded spans indicate those spans for which the application of the new dynamic criteria has resulted in a reduction in span compared with the static design approach previously used.

In the selection of floor joist size for a given span, specifiers should use the above maximum joists spans for guidance and in addition take into account the intended occupancy or use of the floor. Floors supporting partition walls, those constructed using more rigid flooring or including ceiling battens will have improved dynamic performance. These factors may also be taken into consideration.

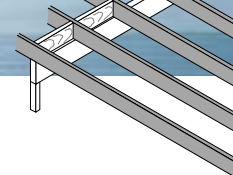

## FLOOR JOISTS

For Tiled Floors or Floors Supporting Heavy Furniture

Design Deflection Limits

D.L.

L.L.

Dynamic Criteria

SPAN/300

SPAN/360

2 mm/1kN

OR 12.5 mm

OR 9 mm

Tiled floors and heavy furniture such as water beds may result in floor joists not designed for these loads deflecting excessively in the long term. The following tables should therefore be used where the loads from floor coverings or furniture are likely to exceed 50 kg/m<sup>2</sup> but are not greater than 100 kg/m<sup>2</sup>.

HYSPAN SECTION D X B (mm)	FLOOR JOIST SPACING (MM)				
	300	400	450	480	600
	MAXIMUM SINGLE SPAN (m)				
95 x 36	2.1	1.8	1.7	1.7	1.7
95 x 45	2.3	1.9	1.9	1.9	1.8
130 x 36	2.9	2.6	2.4	2.5	2.3
130 x 45	3.1	2.8	2.7	2.6	2.5
150 x 36	3.3	3.0	2.9	2.8	2.6
150 x 45	3.5	3.2	3.1	3.0	2.8
170 x 36	3.7	3.4	3.3	3.2	3.0
170 x 45	3.9	3.6	3.5	3.4	3.2
200 x 36*	4.2	3.9	3.8	3.8	3.5
200 x 45	4.4	4.1	4.0	4.0	3.8
240 x 36*	4.8	4.5	4.4	4.3	4.1
240 x 45	5.0	4.7	4.6	4.5	4.3
300 x 45	5.9	5.5	5.4	5.3	5.1
400 x 45*	7.2	6.8	6.6	6.5	6.2
	MAXIMUM CONTINUOUS SPAN (m)				
95 x 36	2.6	2.1	2.0	2.0	1.9
95 x 45	2.8	2.3	2.2	2.2	2.1
130 x 36	3.5	3.1	2.9	2.8	2.7
130 x 45	3.8	3.4	3.2	3.1	3.0
150 x 36	4.0	3.7	3.4	3.3	3.2
150 x 45	4.2	3.9	3.8	3.6	3.5
170 x 36*	4.4	4.1	4.0	3.9	3.7
170 x 45	4.6	4.3	4.2	4.1	3.9
200 x 36*	4.9	4.6	4.5	4.4	4.2
200 x 45	5.2	4.8	4.7	4.6	4.4
240 x 36*	5.6	5.2	5.1	5.0	4.8
240 x 45	5.9	5.5	5.4	5.3	5.0
300 x 45*	6.9	6.5	6.3	6.2	5.9
400 x 45	-	-	-	-	6.8

Joists with D/B >4 should be blocked at supports - see page 20 for details

Joists marked with an \* should be provided with mid-span blocking - see page 20.



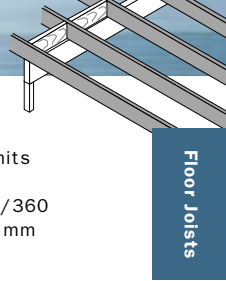

# FLOOR JOISTS

Supporting Parallel Load Bearing Walls Over Openings

Design Deflection Limits  
 D.L. L.L.  
 SPAN/300 SPAN/360  
 OR 12.5 mm OR 9 mm

Floor joists supporting parallel load bearing walls over large spans are likely to deflect excessively even if the ‘rule of thumb’ practice of doubling joists is followed. The following tables give maximum spans for double joists for various roof loads. Roof load width may be determined by reference to the diagrams on page 10.

SHEET ROOF AND CEILING																		
HYSPAN SECTION D X B (mm)	SINGLE SPAN									CONTINUOUS SPAN								
	ROOF LOAD WIDTH ‘RLW’ (m)																	
	1.8	2.4	3.0	3.6	4.2	4.8	5.4	6.0	6.6	1.8	2.4	3.0	3.6	4.2	4.8	5.4	6.0	6.6
MAXIMUM SPAN (m)																		
2/95 x 36	1.9	1.8	1.7	1.6	1.6	1.5	1.5	1.4	1.4	2.5	2.4	2.3	2.2	2.1	2.0	2.0	1.9	1.9
2/95 x 45	2.0	1.9	1.8	1.8	1.7	1.6	1.6	1.5	1.5	2.7	2.6	2.5	2.4	2.3	2.2	2.1	2.1	2.0
2/130 x 36	2.6	2.4	2.3	2.2	2.1	2.1	2.0	2.0	1.9	3.5	3.3	3.1	3.0	2.9	2.8	2.7	2.6	2.6
2/130 x 45	2.8	2.6	2.5	2.4	2.3	2.2	2.2	2.1	2.1	3.7	3.5	3.3	3.2	3.1	3.0	2.9	2.8	2.8
2/150 x 36	3.0	2.8	2.7	2.6	2.5	2.4	2.3	2.3	2.2	4.0	3.8	3.6	3.4	3.3	3.2	3.1	3.0	2.9
2/150 x 45	3.2	3.0	2.9	2.8	2.7	2.6	2.5	2.4	2.4	4.2	4.0	3.8	3.7	3.6	3.4	3.3	3.2	3.2
2/170 x 36	3.4	3.2	3.0	2.9	2.8	2.7	2.6	2.6	2.5	4.3	4.2	4.0	3.9	3.7	3.6	3.5	3.4	3.3
2/170 x 45	3.6	3.4	3.2	3.1	3.0	2.9	2.8	2.7	2.7	4.6	4.4	4.2	4.1	4.0	3.9	3.8	3.7	3.6
2/200 x 36	3.9	3.7	3.5	3.4	3.3	3.2	3.1	3.0	2.9	4.9	4.7	4.5	4.4	4.3	4.2	4.1	4.0	3.9
2/200 x 45	4.1	4.0	3.8	3.7	3.5	3.4	3.3	3.2	3.1	5.1	4.9	4.8	4.6	4.5	4.4	4.3	4.2	4.1
2/240 x 45	4.7	4.5	4.4	4.2	4.1	4.0	3.9	3.9	3.8	5.9	5.6	5.5	5.3	5.1	5.0	4.9	4.8	4.7
2/300 x 45	5.5	5.3	5.2	5.0	4.9	4.8	4.6	4.6	4.5	6.9	6.6	6.4	6.2	6.1	5.9	5.8	5.7	5.6
2/400 x 45	6.8	6.6	6.3	6.2	6.0	5.9	5.7	5.6	5.5	8.5	8.2	7.9	7.7	7.5	7.3	7.2	7.0	6.9

TILE ROOF AND CEILING																		
HYSPAN SECTION D X B (mm)	SINGLE SPAN									CONTINUOUS SPAN								
	ROOF LOAD WIDTH ‘RLW’ (m)																	
	1.8	2.4	3.0	3.6	4.2	4.8	5.4	6.0	6.6	1.8	2.4	3.0	3.6	4.2	4.8	5.4	6.0	6.6
MAXIMUM SPAN (m)																		
2/95 x 36	1.6	1.5	1.4	1.3	1.3	1.2	1.2	1.1	1.1	2.1	2.0	1.9	1.8	1.7	1.6	1.6	1.5	1.5
2/95 x 45	1.7	1.6	1.5	1.4	1.4	1.3	1.3	1.2	1.2	2.3	2.1	2.0	1.9	1.8	1.8	1.7	1.6	1.6
2/130 x 36	2.2	2.0	1.9	1.8	1.7	1.7	1.6	1.6	1.5	2.9	2.7	2.5	2.4	2.3	2.2	2.1	2.1	2.0
2/130 x 45	2.3	2.2	2.0	1.9	1.9	1.8	1.7	1.7	1.6	3.1	2.9	2.7	2.6	2.5	2.4	2.3	2.2	2.2
2/150 x 36	2.5	2.3	2.2	2.1	2.0	1.9	1.8	1.8	1.7	3.3	3.1	2.9	2.8	2.7	2.6	2.5	2.4	2.3
2/150 x 45	2.7	2.5	2.3	2.2	2.1	2.1	2.0	1.9	1.9	3.6	3.3	3.1	3.0	2.9	2.8	2.7	2.6	2.5
2/170 x 36	2.8	2.6	2.5	2.4	2.3	2.2	2.1	2.0	2.0	3.8	3.5	3.3	3.2	3.0	2.9	2.8	2.7	2.6
2/170 x 45	3.0	2.8	2.7	2.5	2.4	2.3	2.2	2.2	2.1	4.0	3.8	3.6	3.4	3.2	3.1	3.0	2.9	2.8
2/200 x 36	3.3	3.1	2.9	2.8	2.6	2.5	2.5	2.4	2.3	4.3	4.1	3.9	3.7	3.5	3.4	3.3	3.2	3.1
2/200 x 45	3.6	3.3	3.1	3.0	2.8	2.7	2.6	2.6	2.5	4.5	4.3	4.1	4.0	3.8	3.7	3.5	3.4	3.3
2/240 x 45	4.2	3.9	3.7	3.6	3.4	3.3	3.2	3.1	3.0	5.2	4.9	4.7	4.5	4.4	4.3	4.2	4.1	4.0
2/300 x 45	4.9	4.6	4.5	4.3	4.2	4.0	3.9	3.8	3.7	6.1	5.8	5.5	5.3	5.2	5.0	4.9	4.8	4.7
2/400 x 45	6.0	5.7	5.5	5.3	5.2	5.0	4.9	4.8	4.7	7.5	7.2	6.9	6.6	6.4	6.2	6.1	5.9	5.8

# LINTELS



## DETERMINATION OF ROOF LOAD WIDTH 'RLW'.

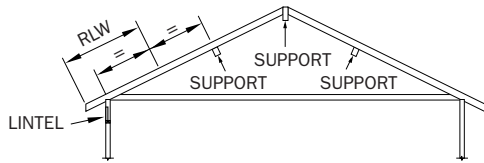

**CONVENTIONAL ROOF**  
COUPLED, STRUTTED RIDGE

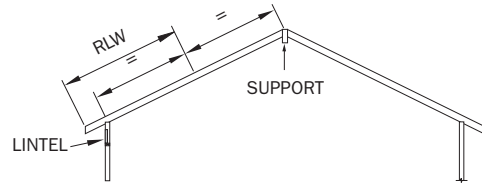

**CATHEDRAL ROOF**

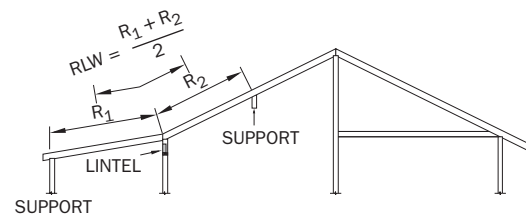

**CATHEDRAL ROOF**

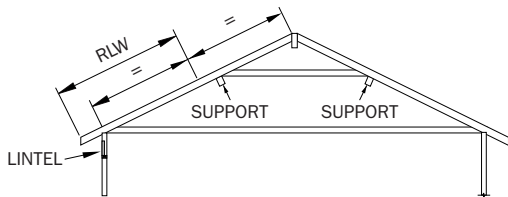

**CONVENTIONAL ROOF**  
COUPLED, UNSTRUTTED RIDGE

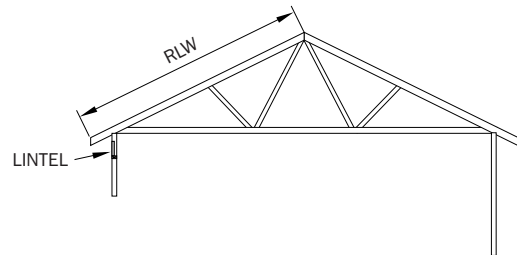

**TRUSSED ROOF**

The diagrams given above may also be used to determine roof load width for bressumers (beams over openings in walls) and garage roof pitching beams, as appropriate.

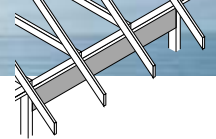

# LINTELS

In Single or Upper Storey Load Bearing External Walls

Design Deflection Limits  
 D.L. L.L.  
 SPAN/300 SPAN/240  
 OR 9 mm OR 9 mm

HYSPAN SECTION D X B (mm)	SHEET ROOF AND CEILING									
	ROOF LOAD WIDTH 'RLW' (m)									
	1.8	2.4	3.0	3.6	4.2	4.8	5.4	6.0	6.6	7.2
	MAXIMUM SPAN (m)									
150 x 36	2.8	2.6	2.5	2.3	2.2	2.1	2.0	2.0	1.9	1.8
150 x 45	3.0	2.8	2.6	2.5	2.4	2.3	2.2	2.1	2.1	2.0
170 x 36	3.1	2.9	2.8	2.6	2.5	2.4	2.3	2.1	2.0	2.0
170 x 45	3.2	3.0	2.9	2.8	2.7	2.6	2.5	2.4	2.3	2.3
200 x 36	3.5	3.2	3.1	3.0	2.8	2.7	2.5	2.4	2.3	2.2
200 x 45	3.7	3.4	3.2	3.1	3.0	2.9	2.8	2.8	2.7	2.6
200 x 63	3.9	3.7	3.5	3.4	3.2	3.1	3.0	3.0	2.9	2.9
240 x 36	4.0	3.7	3.5	3.4	3.1	2.9	2.7	2.6	2.5	2.4
240 x 45	4.2	3.9	3.7	3.5	3.4	3.3	3.2	3.1	3.1	3.0
240 x 63	4.5	4.2	4.0	3.8	3.7	3.6	3.5	3.4	3.3	3.3
300 x 45	4.9	4.6	4.4	4.2	4.0	3.9	3.8	3.6	3.5	3.3
300 x 63	5.3	5.0	4.7	4.5	4.4	4.2	4.1	4.0	3.9	3.8
300 x 75	5.5	5.1	4.9	4.7	4.5	4.4	4.3	4.2	4.1	4.0
2/300 x 45*	5.7	5.4	5.1	4.9	4.7	4.6	4.5	4.4	4.3	4.2
360 x 63	6.0	5.6	5.4	5.2	5.0	4.8	4.7	4.6	4.5	4.4
400 x 45	6.0	5.7	5.3	4.9	4.5	4.2	4.0	3.7	3.6	3.4
400 x 63	6.5	6.1	5.8	5.6	5.4	5.2	5.1	4.9	4.8	4.7
400 x 75	6.7	6.3	6.0	5.8	5.6	5.4	5.3	5.2	5.0	4.9
2/400 x 45*	6.9	6.6	6.3	6.0	5.8	5.7	5.5	5.3	5.1	4.9
450 x 63	7.0	6.6	6.3	6.1	5.9	5.7	5.5	5.4	5.3	5.0

HYSPAN SECTION D X B (mm)	TILE ROOF AND CEILING									
	ROOF LOAD WIDTH 'RLW' (m)									
	1.8	2.4	3.0	3.6	4.2	4.8	5.4	6.0	6.6	7.2
	MAXIMUM SPAN (m)									
150 x 36	2.2	2.0	1.9	1.8	1.7	1.7	1.6	1.5	1.5	1.5
150 x 45	2.4	2.2	2.0	1.9	1.8	1.8	1.7	1.6	1.6	1.6
170 x 36	2.5	2.3	2.1	2.0	1.9	1.9	1.8	1.7	1.7	1.6
170 x 45	2.7	2.5	2.3	2.2	2.1	2.0	1.9	1.8	1.8	1.7
200 x 36	2.9	2.7	2.5	2.4	2.2	2.2	2.1	2.0	1.9	1.9
200 x 45	3.0	2.8	2.7	2.5	2.4	2.3	2.2	2.2	2.1	2.0
200 x 63	3.3	3.0	2.9	2.8	2.7	2.6	2.5	2.4	2.3	2.3
240 x 36	3.3	3.0	2.9	2.8	2.7	2.6	2.5	2.4	2.3	2.3
240 x 45	3.4	3.2	3.0	2.9	2.8	2.7	2.7	2.6	2.5	2.4
240 x 63	3.7	3.5	3.3	3.2	3.0	3.0	2.9	2.8	2.8	2.7
300 x 45	4.1	3.8	3.6	3.4	3.3	3.2	3.1	3.0	3.0	2.9
300 x 63	4.4	4.1	3.9	3.7	3.6	3.5	3.4	3.3	3.2	3.1
300 x 75	4.6	4.3	4.1	3.9	3.7	3.6	3.5	3.4	3.4	3.3
2/300 x 45*	4.8	4.5	4.2	4.1	3.9	3.8	3.7	3.6	3.5	3.4
360 x 63	5.0	4.7	4.5	4.3	4.1	4.0	3.9	3.8	3.7	3.6
400 x 45	5.0	4.7	4.4	4.3	4.1	4.0	3.9	3.8	3.7	3.6
400 x 63	5.4	5.1	4.8	4.6	4.4	4.3	4.2	4.1	4.0	3.9
400 x 75	5.6	5.3	5.0	4.8	4.6	4.5	4.4	4.3	4.2	4.1
2/400 x 45*	5.9	5.5	5.2	5.0	4.8	4.7	4.6	4.4	4.3	4.3
450 x 63	5.9	5.5	5.2	5.0	4.8	4.7	4.6	4.4	4.3	4.3

\*Size built-up by vertical nail lamination - see page 5.

FOR DETERMINATION OF ROOF LOAD WIDTH - SEE PAGE 24

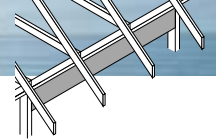

# LINTELS

In Lower Storey Load Bearing External Walls

Design Deflection Limits  
 D.L. L.L.  
 SPAN/300 SPAN/240  
 OR 9 mm OR 9 mm

Lintels

SHEET ROOF AND CEILING															
HYSPAN SECTION D X B (mm)	FLOOR LOAD WIDTH 'FLW' (m)														
	1.8					2.4					3.0				
	ROOF LOAD WIDTH 'RLW' (m)														
	1.8	3.0	4.2	5.4	6.6	1.8	3.0	4.2	5.4	6.6	1.8	3.0	4.2	5.4	6.6
MAXIMUM SPAN (m)															
150 x 36	1.8	1.7	1.6	1.6	1.5	1.7	1.6	1.6	1.5	1.5	1.6	1.5	1.5	1.5	1.4
150 x 45	1.9	1.8	1.7	1.7	1.6	1.8	1.7	1.7	1.6	1.6	1.7	1.7	1.6	1.6	1.5
150 x 75	2.2	2.1	2.1	2.0	1.9	2.1	2.0	2.0	1.9	1.9	2.0	2.0	1.9	1.8	1.8
170 x 36	2.0	1.9	1.8	1.8	1.7	1.9	1.8	1.8	1.7	1.6	1.8	1.7	1.7	1.6	1.6
170 x 45	2.1	2.0	2.0	1.9	1.8	2.0	2.0	1.9	1.8	1.8	1.9	1.9	1.8	1.8	1.7
200 x 36	2.3	2.2	2.1	2.1	2.0	2.2	2.1	2.1	2.0	1.9	2.1	2.1	2.0	1.9	1.9
200 x 45	2.5	2.4	2.3	2.2	2.2	2.4	2.3	2.2	2.1	2.1	2.3	2.2	2.1	2.1	2.0
200 x 63	2.8	2.7	2.6	2.5	2.4	2.7	2.6	2.5	2.4	2.3	2.6	2.5	2.4	2.3	2.3
2/200 x 36*	2.9	2.8	2.7	2.6	2.5	2.8	2.7	2.6	2.5	2.4	2.7	2.6	2.5	2.4	2.4
240 x 36	2.8	2.7	2.6	2.5	2.4	2.7	2.6	2.5	2.4	2.3	2.5	2.5	2.4	2.3	2.2
240 x 45	2.9	2.8	2.7	2.7	2.6	2.8	2.7	2.7	2.6	2.5	2.7	2.6	2.6	2.5	2.4
240 x 63	3.2	3.1	3.0	2.9	2.8	3.1	3.0	2.9	2.8	2.8	3.0	2.9	2.8	2.8	2.7
2/240 x 36*	3.3	3.2	3.1	3.0	2.9	3.2	3.1	3.0	2.9	2.9	3.1	3.0	2.9	2.8	2.8
2/240 x 45*	3.5	3.4	3.3	3.2	3.1	3.3	3.2	3.2	3.1	3.0	3.2	3.1	3.1	3.0	2.9
300 x 45	3.5	3.3	3.2	3.2	3.1	3.3	3.2	3.1	3.1	3.0	3.2	3.1	3.1	3.0	2.9
300 x 63	3.8	3.6	3.5	3.4	3.3	3.6	3.5	3.4	3.3	3.3	3.5	3.4	3.3	3.3	3.2
300 x 75	3.9	3.8	3.7	3.6	3.5	3.8	3.7	3.6	3.5	3.4	3.6	3.6	3.5	3.4	3.3
2/300 x 45*	4.1	4.0	3.8	3.7	3.6	3.9	3.8	3.7	3.6	3.6	3.8	3.7	3.6	3.5	3.5
360 x 63	4.3	4.2	4.0	3.9	3.8	4.1	4.0	3.9	3.8	3.7	4.0	3.9	3.8	3.7	3.7
400 x 45	4.3	4.1	4.0	3.9	3.8	4.1	4.0	3.9	3.8	3.7	4.0	3.9	3.8	3.7	3.6
400 x 63	4.6	4.5	4.4	4.2	4.1	4.5	4.3	4.2	4.1	4.0	4.3	4.2	4.1	4.0	4.0
400 x 75	4.8	4.7	4.5	4.4	4.3	4.7	4.5	4.4	4.3	4.2	4.5	4.4	4.3	4.2	4.1
450 x 63	5.1	4.9	4.8	4.6	4.5	4.9	4.7	4.6	4.5	4.4	4.7	4.6	4.5	4.4	4.3

\*Size built-up by vertical nail lamination - see page 5

FOR DETERMINATION OF FLOOR LOAD WIDTHS AND ROOF LOAD WIDTH - SEE PAGE 10

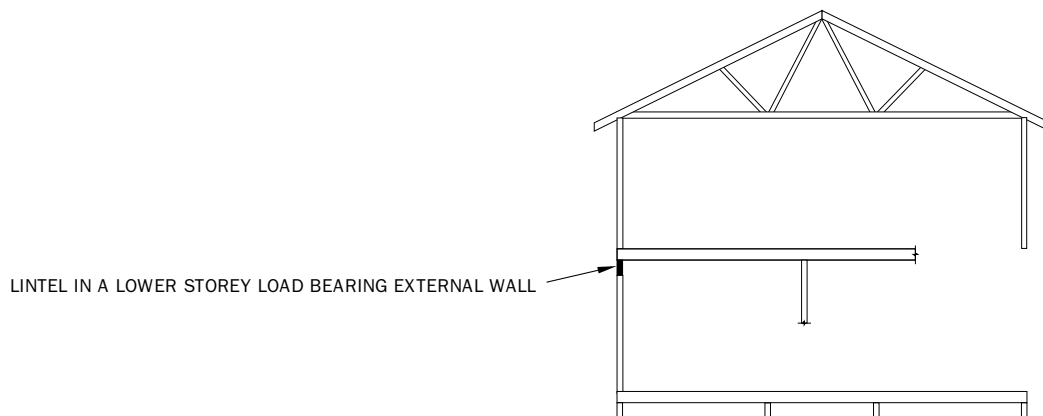

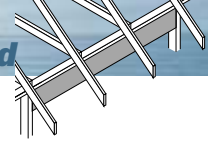

# LINTELS

*In Lower Storey Load Bearing External Walls*

Design Deflection Limits  
 D.L. L.L.  
 SPAN/300 SPAN/240  
 OR 9 mm OR 9 mm

Lintels

TILE ROOF AND CEILING															
HYSPAN SECTION D X B (mm)	FLOOR LOAD WIDTH 'FLW' (m)														
	1.8					2.4					3.0				
	ROOF LOAD WIDTH 'RLW' (m)														
	1.8	3.0	4.2	5.4	6.6	1.8	3.0	4.2	5.4	6.6	1.8	3.0	4.2	5.4	6.6
150 x 36	1.6	1.5	1.4	1.3	1.3	1.6	1.5	1.4	1.3	1.3	1.5	1.4	1.3	1.3	1.2
150 x 45	1.7	1.6	1.5	1.4	1.4	1.7	1.6	1.5	1.4	1.3	1.6	1.5	1.4	1.4	1.3
150 x 75	2.1	1.9	1.8	1.7	1.6	2.0	1.8	1.7	1.7	1.6	1.9	1.8	1.7	1.6	1.6
170 x 36	1.8	1.7	1.6	1.5	1.4	1.8	1.6	1.6	1.5	1.4	1.7	1.6	1.5	1.4	1.4
170 x 45	2.0	1.8	1.7	1.6	1.6	1.9	1.8	1.7	1.6	1.5	1.8	1.7	1.6	1.6	1.5
200 x 36	2.2	2.0	1.9	1.8	1.7	2.1	1.9	1.8	1.7	1.7	2.0	1.9	1.8	1.7	1.6
200 x 45	2.3	2.1	2.0	1.9	1.8	2.2	2.1	2.0	1.9	1.8	2.1	2.0	1.9	1.8	1.8
200 x 63	2.6	2.4	2.2	2.1	2.0	2.5	2.3	2.2	2.1	2.0	2.4	2.2	2.1	2.0	2.0
2/200 x 36*	2.7	2.5	2.3	2.2	2.1	2.6	2.4	2.3	2.2	2.1	2.5	2.3	2.2	2.1	2.0
240 x 36	2.6	2.4	2.2	2.1	2.0	2.5	2.3	2.2	2.1	2.0	2.4	2.2	2.1	2.0	2.0
240 x 45	2.8	2.6	2.4	2.3	2.2	2.7	2.5	2.3	2.2	2.1	2.6	2.4	2.3	2.2	2.1
240 x 63	3.0	2.8	2.7	2.6	2.4	2.9	2.8	2.6	2.5	2.4	2.8	2.7	2.6	2.4	2.3
2/240 x 36*	3.1	2.9	2.8	2.7	2.6	3.0	2.8	2.7	2.6	2.5	2.9	2.8	2.7	2.6	2.5
2/240 x 45*	3.3	3.1	2.9	2.8	2.7	3.2	3.0	2.9	2.8	2.7	3.1	2.9	2.8	2.7	2.6
300 x 45	3.3	3.1	2.9	2.8	2.7	3.2	3.0	2.9	2.8	2.7	3.1	2.9	2.8	2.7	2.6
300 x 63	3.5	3.3	3.2	3.1	3.0	3.4	3.3	3.1	3.0	2.9	3.3	3.2	3.1	3.0	2.9
300 x 75	3.7	3.5	3.3	3.2	3.1	3.6	3.4	3.3	3.1	3.0	3.5	3.3	3.2	3.1	3.0
2/300 x 45*	3.9	3.6	3.5	3.3	3.2	3.7	3.5	3.4	3.3	3.2	3.6	3.5	3.3	3.2	3.1
360 x 63	4.0	3.8	3.6	3.5	3.4	3.9	3.7	3.6	3.4	3.3	3.8	3.6	3.5	3.4	3.3
400 x 45	4.0	3.8	3.6	3.5	3.4	3.9	3.7	3.6	3.4	3.3	3.8	3.6	3.5	3.4	3.3
400 x 63	4.4	4.1	3.9	3.8	3.7	4.2	4.0	3.9	3.7	3.6	4.1	3.9	3.8	3.7	3.6
400 x 75	4.6	4.3	4.1	4.0	3.8	4.4	4.2	4.0	3.9	3.8	4.3	4.1	4.0	3.8	3.7
450 x 63	4.8	4.5	4.3	4.1	4.0	4.6	4.4	4.2	4.1	3.9	4.5	4.3	4.1	4.0	3.9

\*Size built-up by vertical nail lamination - see page 5

FOR DETERMINATION OF FLOOR LOAD WIDTHS AND ROOF LOAD WIDTH - SEE PAGE 10

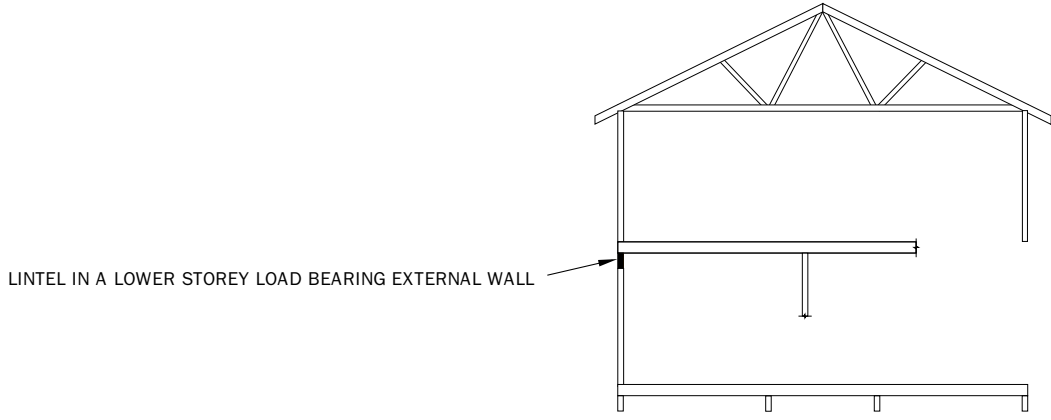

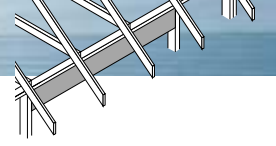

# LINTELS

## Supporting Truncated Girder Truss

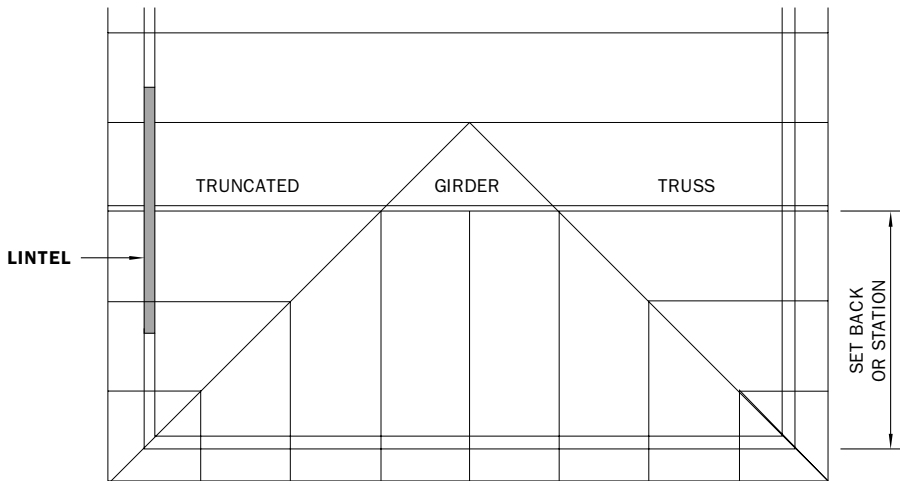
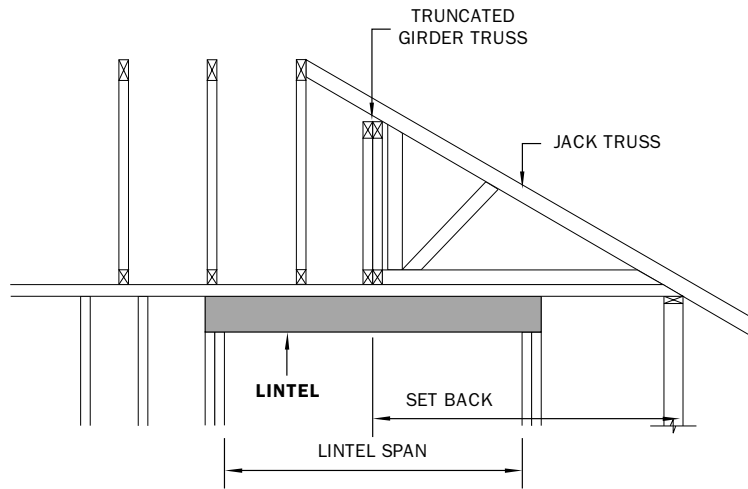
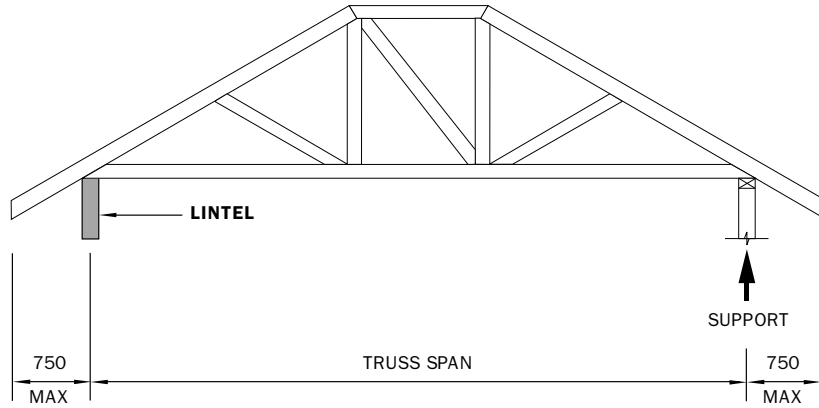



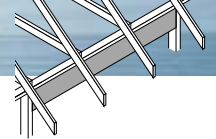

# LINTELS

## Supporting Truncated Girder Truss

Design Deflection Limits  
 D.L. L.L.  
 SPAN/300 SPAN/240  
 OR 9 mm OR 9 mm

2400 SETBACK						
HYSPAN SECTION D X B (mm)	SHEET ROOF AND CEILING			TILE ROOF AND CEILING		
	TRUSS SPAN (m)			TRUSS SPAN (m)		
	6.0	7.5	9.0	6.0	7.5	9.0
MAXIMUM SPAN (m)						
130 x 36	1.7	1.6	1.5	1.3	1.1	1.0 ▲●
130 x 45	1.9	1.7	1.6	1.4	1.3	1.2 ●
150 x 36	2.0	1.9	1.8	1.5	1.3	1.2 ▲●
150 x 45	2.2	2.1	1.9	1.6	1.5	1.4
170 x 36	2.2	2.0	1.7	1.7	1.5 ▲	1.4 ▲●
170 x 45	2.6	2.4	2.2	1.9	1.7	1.6 ▲
200 x 45	3.0	2.8	2.7	2.3	2.1	2.0 ▲
200 x 63	3.2	3.1	3.0	2.6	2.4	2.3
2/200 x 45*	3.5	3.4	3.3	2.9	2.7	2.6
240 x 45	3.4	3.3	3.1	2.8	2.6 ▲	2.5 ▲
240 x 63	3.7	3.6	3.4	3.0	2.9	2.8
2/240 x 45*	4.1	3.9	3.8	3.3	3.2	3.0
300 x 45	4.1	3.9	3.8	3.3 ▲	3.2 ▲	3.0 ▲
300 x 63	4.5	4.3	4.1	3.6	3.5	3.3 ▲
300 x 75	4.7	4.5	4.3	3.8	3.6	3.5
2/300 x 45*	4.9	4.7	4.5	4.0	3.8	3.7
360 x 63	5.1	4.9	4.8	4.2	4.0 ▲	3.9 ▲
400 x 63	5.6	5.4	5.2	4.6	4.4 ▲	4.2 ▲
400 x 75	5.8	5.6	5.4	4.8	4.6	4.4 ▲
450 x 63	6.1	5.9	5.7	5.0 ▲	4.8 ▲	4.6 ▲

3600 SETBACK						
HYSPAN SECTION D X B (mm)	SHEET ROOF AND CEILING			TILE ROOF AND CEILING		
	TRUSS SPAN (m)			TRUSS SPAN (m)		
	9.0	10.5	12.0	9.0	10.5	12.0
MAXIMUM SPAN (m)						
130 x 36	1.4	1.2	1.1	-	-	-
130 x 45	1.5	1.4	1.3	-	-	-
150 x 36	1.6	1.5	1.3	-	-	-
150 x 45	1.8	1.7	1.6	1.3 ▲	1.2 ▲●	-
170 x 36	1.5	1.3	1.2	1.2 ▲	1.0 ■●	0.9 ■●
170 x 45	1.9	1.7	1.5	1.5 ▲	1.4 ▲	1.2 ▲
200 x 45	2.4	2.1	1.9	1.8 ▲●	1.7 ▲●	1.5 ■●
200 x 63	2.8	2.7	2.5	2.1 ▲	2.0 ▲	1.9 ▲
2/200 x 45*	3.1	3.0	2.9	2.4	2.3	2.2
240 x 45	3.0	2.7	2.4	2.3 ●	2.1 ■●	1.9 ■●
240 x 63	3.3	3.2	3.1	2.6 ▲	2.5 ▲	2.3 ▲
2/240 x 45*	3.6	3.5	3.4	2.9	2.8	2.7 ▲
300 x 45	3.6	3.4	3.1 ▲	2.9 ■●	2.6 ■●	2.4 ■●
300 x 63	4.0	3.8	3.7	3.2 ▲	3.1 ▲	3.0 ▲
300 x 75	4.1	4.0	3.9	3.3 ▲	3.2 ▲	3.1 ▲
2/300 x 45*	4.3	4.2	4.1	3.5	3.4 ▲	3.3 ▲
360 x 63	4.6	4.4	4.3	3.7 ▲	3.6 ▲	3.4 ■
400 x 63	5.0	4.8	4.7	4.0 ▲	3.9 ▲	3.8 ■
400 x 75	5.2	5.0	4.9	4.2 ▲	4.1 ▲	3.9 ▲
450 x 63	5.5	5.3	5.1	4.4 ▲	4.3 ■	4.1 ■

Maximum truss or rafter spacing – 900 mm

\* Size built-up by vertical nail lamination. See page 5.

▲ Minimum bearing area – 45 x thickness of lintel

■ Minimum bearing area – 70 x thickness of lintel

● Truncated Girder Truss should be located within the middle third of the lintel span otherwise shear strength may be exceeded.

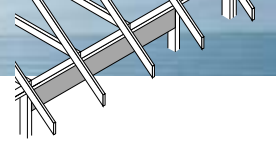

# LINTELS SUPPORTING STRUTTING BEAMS

*Strutting Beam Supporting Underpurlins and Hanging Beams*

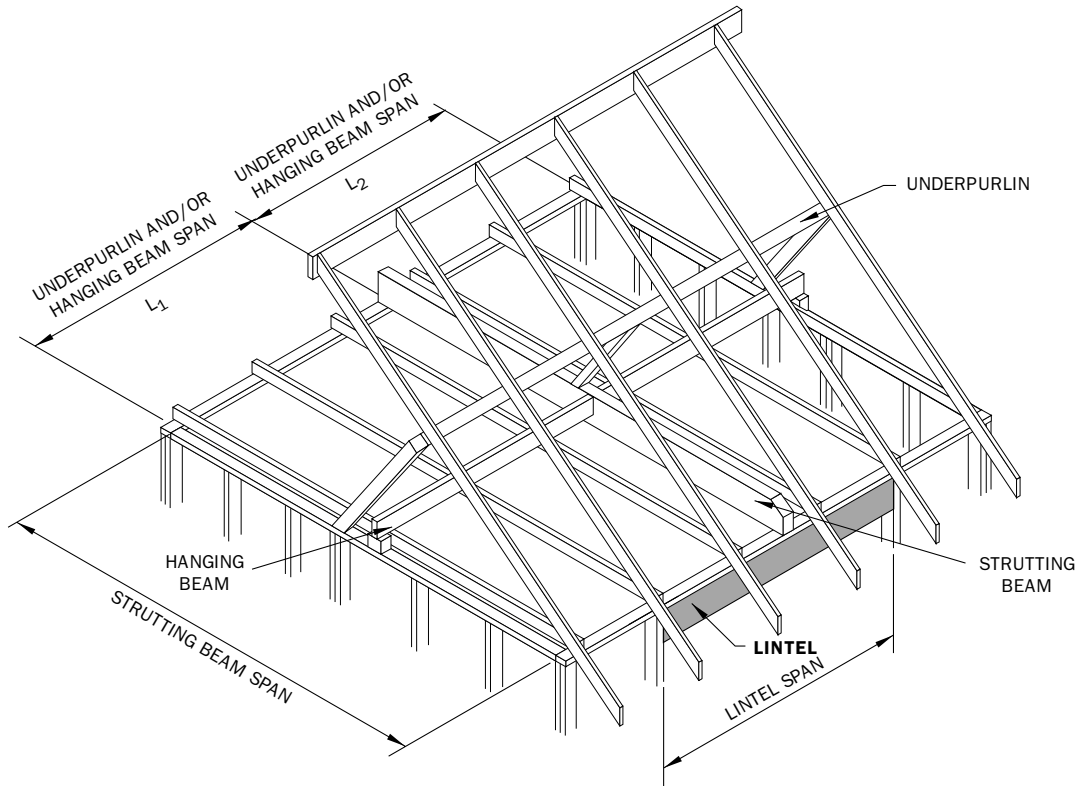

$$\text{Hanging beam/underpurlin span} = \frac{1}{2} (L_1 + L_2).$$

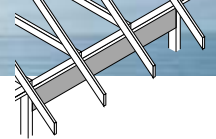

# LINTELS SUPPORTING STRUTTING BEAMS

*Strutting Beam Supporting Underpurlins and Hanging Beams*

Design Deflection Limits  
 D.L. L.L.  
 SPAN/300 SPAN/240  
 OR 9 mm OR 9 mm

HYSPAN SECTION D X B (mm)	MAXIMUM HANGING BEAM AND/OR UNDERPURLIN SPANS (m)	SHEET ROOF AND CEILING					TILE ROOF AND CEILING				
		STRUTTING BEAM SPAN (m)									
		3.6	4.2	4.8	5.4	6.0	3.6	4.2	4.8	5.4	6.0
MAXIMUM SPAN (m)											
130 x 36	2.4	2.0	1.9	1.8	1.7	1.6	1.4	1.3	1.2	1.2	1.1
	4.2	1.6	1.6	1.5	1.5	1.4	1.1	1.0	0.9	0.8	-
130 x 45	2.4	2.1	2.0	1.9	1.9	1.8	1.5	1.4	1.4	1.3	1.3
	4.2	1.8	1.8	1.7	1.6	1.6	1.3	1.2	1.2	1.1	1.1
150 x 45	2.4	2.5	2.4	2.3	2.2	2.1	1.8	1.7	1.6	1.6	1.5
	4.2	2.1	2.1	2.0	1.9	1.9	1.5	1.5	1.4	1.3	1.3
150 x 63	2.4	2.8	2.7	2.6	2.5	2.4	2.1	1.9	1.9	1.8	1.7
	4.2	2.4	2.4	2.3	2.2	2.1	1.7	1.7	1.6	1.6	1.5
150 x 75	2.4	3.0	2.9	2.8	2.7	2.6	2.2	2.1	2.0	1.9	1.8
	2.6	2.6	2.6	2.5	2.4	2.3	1.8	1.8	1.8	1.7	1.6
170 x 45	2.4	2.9	2.8	2.7	2.6	2.5	2.1	2.0	1.9	1.8	1.7
	4.2	2.5	2.5	2.4	2.3	2.2	1.7	1.7	1.7	1.6	1.5
170 x 63	2.4	3.1	3.0	2.9	2.9	2.8	2.4	2.2	2.1	2.1	2.0
	4.2	2.8	2.8	2.7	2.6	2.5	2.0	2.0	1.9	1.8	1.8
200 x 36	2.4	3.1	3.0	2.9	2.8	2.7	2.3	2.2	2.0	1.9	1.7
	4.2	2.7	2.7	2.7	2.5	2.4	1.7	1.7	1.6	1.4	1.3
200 x 45	2.4	3.3	3.2	3.1	3.0	2.9	2.5	2.4	2.3	2.2	2.1
	4.2	2.9	2.9	2.8	2.8	2.7	2.1	2.1	2.0	1.9	1.9
200 x 63	2.4	3.6	3.5	3.4	3.3	3.2	2.8	2.7	2.6	2.5	2.4
	4.2	3.2	3.2	3.1	3.0	3.0	2.4	2.4	2.3	2.2	2.1
240 x 45	2.4	3.8	3.7	3.6	3.5	3.4	3.0	2.9	2.8	2.7	2.6
	4.2	3.4	3.4	3.3	3.2	3.1	2.6	2.6	2.5	2.4	2.3
240 x 63	2.4	4.2	4.0	3.9	3.8	3.7	3.3	3.1	3.1	3.0	2.9
	4.2	3.7	3.7	3.7	3.6	3.5	2.9	2.9	2.9	2.8	2.7
2/240 x 45*	2.4	4.6	4.4	4.3	4.2	4.1	3.6	3.5	3.4	3.3	3.2
	4.2	4.1	4.1	4.1	3.9	3.8	3.2	3.2	3.2	3.1	3.0
300 x 63	2.4	5.0	4.8	4.7	4.6	4.4	3.9	3.8	3.7	3.6	3.5
	4.2	4.4	4.4	4.4	4.3	4.2	3.5	3.5	3.5	3.3	3.3
300 x 75	2.4	5.2	5.0	4.9	4.8	4.7	4.1	4.0	3.8	3.7	3.6
	4.2	4.7	4.7	4.6	4.5	4.4	3.6	3.6	3.6	3.5	3.4
2/300 x 45*	2.4	5.5	5.3	5.1	5.0	4.9	4.3	4.2	4.0	3.9	3.8
	4.2	4.9	4.9	4.9	4.8	4.6	3.8	3.8	3.8	3.7	3.6
360 x 63	2.4	5.8	5.6	5.4	5.3	5.2	4.5	4.4	4.2	4.1	4.0
	4.2	5.2	5.2	5.2	5.0	4.9	4.0	4.0	4.0	3.9	3.8
400 x 63	2.4	6.3	6.1	5.9	5.7	5.6	4.9	4.8	4.6	4.5	4.4
	4.2	5.6	5.6	5.6	5.5	5.3	4.4	4.4	4.4	4.3	4.2
400 x 75	2.4	6.6	6.3	6.2	6.0	5.9	5.2	5.0	4.8	4.7	4.6
	4.2	5.9	5.9	5.9	5.7	5.6	4.6	4.6	4.6	4.3	4.0
450 x 63	2.4	6.9	6.7	6.5	6.3	6.2	5.4	5.2	5.1	4.9	4.8
	4.2	6.2	6.2	6.2	6.0	5.9	4.8	4.8	4.8	4.7	4.6

\*Size built-up by vertical nail lamination - see page 5.

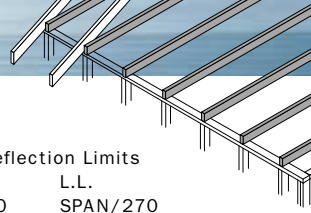

# CEILING JOISTS

Supporting Ceiling Lining only

Design Deflection Limits  
 D.L. L.L.  
 SPAN/400 SPAN/270  
 OR 12.5 mm OR 15 mm

Ceiling Joists

HYSPAN SECTION D X B (mm)	SINGLE SPAN				CONTINUOUS SPAN			
	CEILING JOIST SPACING (mm)							
	450	600	900	1200	450	600	900	1200
	MAXIMUM SPAN (m)							
95 x 36	2.3	2.3	2.5	2.4	2.8	2.8	3.0	2.9
95 x 45	2.6	2.6	2.8	2.7	3.1	3.1	3.4	3.3
130 x 36	3.7	3.7	3.7	3.4	4.3	4.3	4.6	4.2
130 x 45	4.1	4.1	3.9	3.6	4.6	4.6	4.8	4.5
150 x 36	4.4	4.4	4.2	3.9	5.0	5.0	5.2	4.8
150 x 45	4.8	4.8	4.5	4.1	5.3	5.3	5.4	5.1
170 x 36	5.0	5.0	4.7	4.4	5.6	5.6	5.6	5.3
170 x 45	5.4	5.4	5.0	4.7	6.0	6.0	5.9	5.6
200 x 36	5.9	5.8	5.4	5.1	6.6	6.6	6.3	6.0
200 x 45	6.2	6.0	5.6	5.3	7.1	7.0	6.5	6.2
240 x 36	6.8	6.5	6.1	5.8	7.9	7.6	7.1	6.8
240 x 45	7.0	6.7	6.3	6.0	8.2	7.9	7.4	7.0
300 x 45	8.0	7.7	7.3	7.0	-	-	-	-

- ☐ Shaded areas indicate that a permanent batten should be fixed at mid span to the top of all joists and braced back to a point of rigidity to prevent rollover under construction and maintenance loads.
- Mass of ceiling lining (and battens, if appropriate) not to exceed 15 kg/m<sup>2</sup>.
- Ceiling joists not fixed to rafters and having D/B >4 should be blocked at supports to prevent rollover.

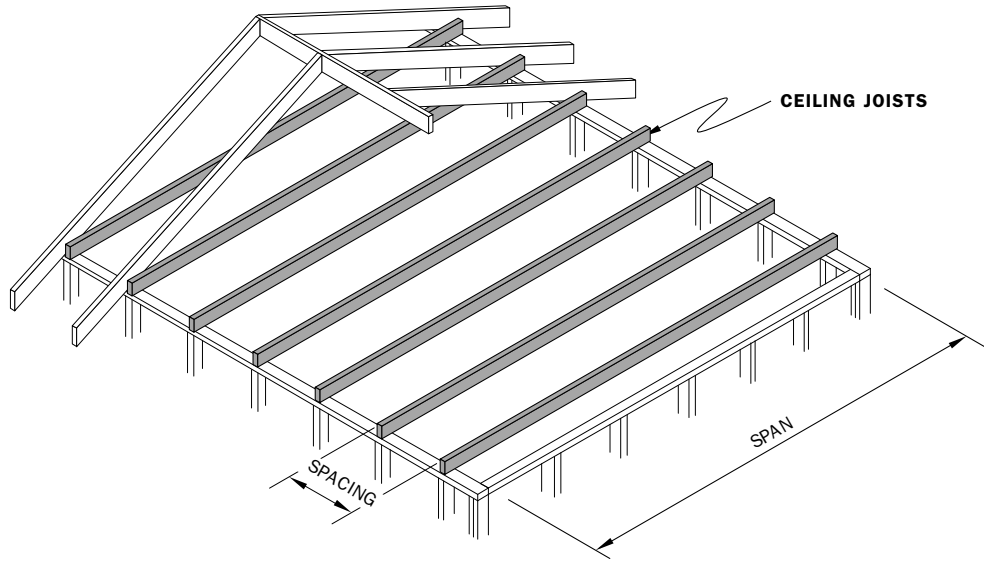

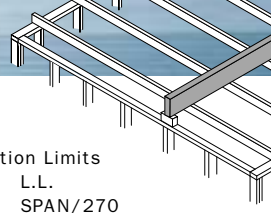

Design Deflection Limits  
 D.L. L.L.  
 SPAN/300 SPAN/270  
 OR 12.5 mm OR 15 mm

# HANGING BEAMS

Supporting Ceiling Joists

Hanging Beams  
Ceiling Joists

HYSpan SECTION D X B (mm)	CEILING LOAD WIDTH 'CLW' (m)									
	1.2	1.5	1.8	2.1	2.4	2.7	3.0	3.6	4.2	4.8
	MAXIMUM SPAN (m)									
150 x 36	3.9	3.7	3.5	3.4	3.2	3.1	3.0	2.8	2.7	2.6
150 x 45	4.1	3.9	3.8	3.6	3.4	3.3	3.2	3.0	2.9	2.8
150 x 75	4.6	4.4	4.2	4.1	3.9	3.8	3.8	3.6	3.4	3.3
170 x 45	4.5	4.3	4.1	4.0	3.9	3.8	3.6	3.4	3.3	3.1
170 x 63	4.8	4.6	4.4	4.3	4.2	4.1	4.0	3.8	3.6	3.5
200 x 36	4.8	4.6	4.4	4.3	4.1	4.0	3.9	3.8	3.6	3.4
200 x 45	5.0	4.8	4.6	4.5	4.3	4.2	4.1	4.0	3.8	3.7
200 x 63	5.4	5.2	5.0	4.8	4.7	4.6	4.5	4.3	4.1	4.0
240 x 36	5.5	5.2	5.0	4.9	4.7	4.6	4.5	4.3	4.1	4.0
240 x 45	5.7	5.5	5.3	5.1	5.0	4.8	4.7	4.5	4.4	4.2
240 x 63	6.1	5.8	5.6	5.5	5.3	5.2	5.1	4.9	4.7	4.6
300 x 45	6.7	6.4	6.2	6.0	5.8	5.7	5.5	5.3	5.1	5.0
300 x 63	7.1	6.8	6.6	6.4	6.2	6.1	5.9	5.7	5.5	5.4
300 x 75	7.3	7.0	6.8	6.6	6.4	6.3	6.2	5.9	5.7	5.6
360 x 63	8.0	7.7	7.5	7.3	7.1	6.9	6.8	6.5	6.3	6.1
400 x 45	8.1	7.8	7.5	7.3	7.1	7.0	6.8	6.5	6.3	6.1
400 x 63	8.6	8.3	8.0	7.8	7.6	7.4	7.3	7.0	6.8	6.6
400 x 75	8.8	8.5	8.3	8.0	7.9	7.7	7.5	7.3	7.0	6.9
450 x 63	9.2	8.9	8.7	8.4	8.2	8.1	7.9	7.6	7.4	7.2
525 x 75	10.4	10.1	9.9	9.6	9.4	9.2	9.1	8.8	8.5	8.3

FOR DETERMINATION OF CEILING LOAD WIDTH 'CLW' SEE THE DIAGRAM BELOW

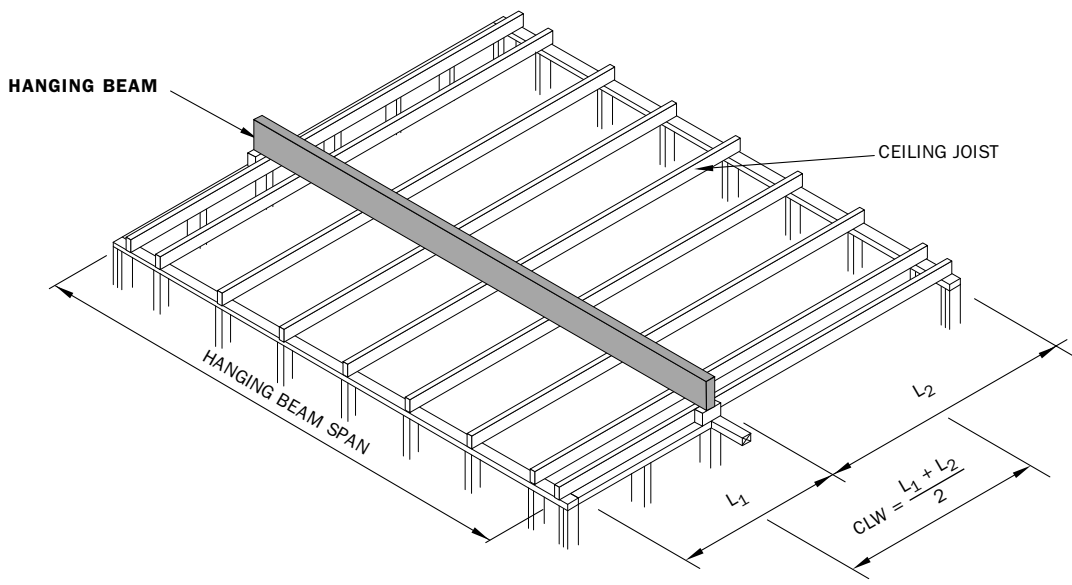

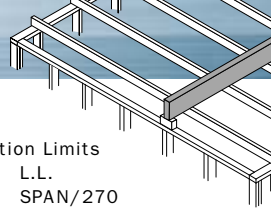

Design Deflection Limits  
 D.L. L.L.  
 SPAN/300 SPAN/270  
 OR 12.5 mm OR 15 mm

# COUNTER BEAMS

Supporting Hanging Beams

Counter Beams

HYSPAN SECTION D X B (mm)	CEILING LOAD WIDTH 'CLW' (m)							
	2.4	3.0	3.6	4.2	4.8	5.4	6.0	6.6
	MAXIMUM SPAN (m)							
150 x 36	3.4	3.2	3.0	2.9	2.8	2.7	2.6	2.5
150 x 45	3.7	3.4	3.3	3.1	3.0	2.9	2.8	2.7
170 x 36	3.9	3.6	3.4	3.3	3.1	3.0	2.9	2.8
170 x 45	4.1	3.9	3.7	3.5	3.4	3.2	3.1	3.0
200 x 36	4.3	4.1	4.0	3.8	3.7	3.5	3.4	3.3
200 x 45	4.6	4.3	4.2	4.0	3.9	3.8	3.7	3.6
200 x 63	4.9	4.7	4.5	4.3	4.2	4.1	4.0	3.9
240 x 36	5.0	4.7	4.5	4.4	4.2	4.1	4.0	3.9
240 x 45	5.2	5.0	4.8	4.6	4.5	4.3	4.2	4.1
240 x 63	5.6	5.3	5.1	5.0	4.8	4.7	4.6	4.5
300 x 45	6.1	5.8	5.6	5.4	5.2	5.1	5.0	4.9
300 x 63	6.5	6.2	6.0	5.8	5.6	5.5	5.4	5.3
300 x 75	6.7	6.4	6.2	6.0	5.9	5.7	5.6	5.5
360 x 63	7.4	7.1	6.8	6.6	6.4	6.3	6.1	6.0
400 x 45	7.4	7.1	6.9	6.6	6.4	6.3	6.1	6.0
400 x 63	7.9	7.6	7.3	7.1	6.9	6.8	6.6	6.5
400 x 75	8.2	7.9	7.6	7.4	7.2	7.0	6.9	6.7
450 x 63	8.6	8.2	8.0	7.7	7.5	7.3	7.2	7.0
525 x 75	9.8	9.4	9.1	8.9	8.7	8.5	8.3	8.1

FOR DETERMINATION OF CEILING LOAD WIDTH 'CLW' SEE THE DIAGRAM BELOW

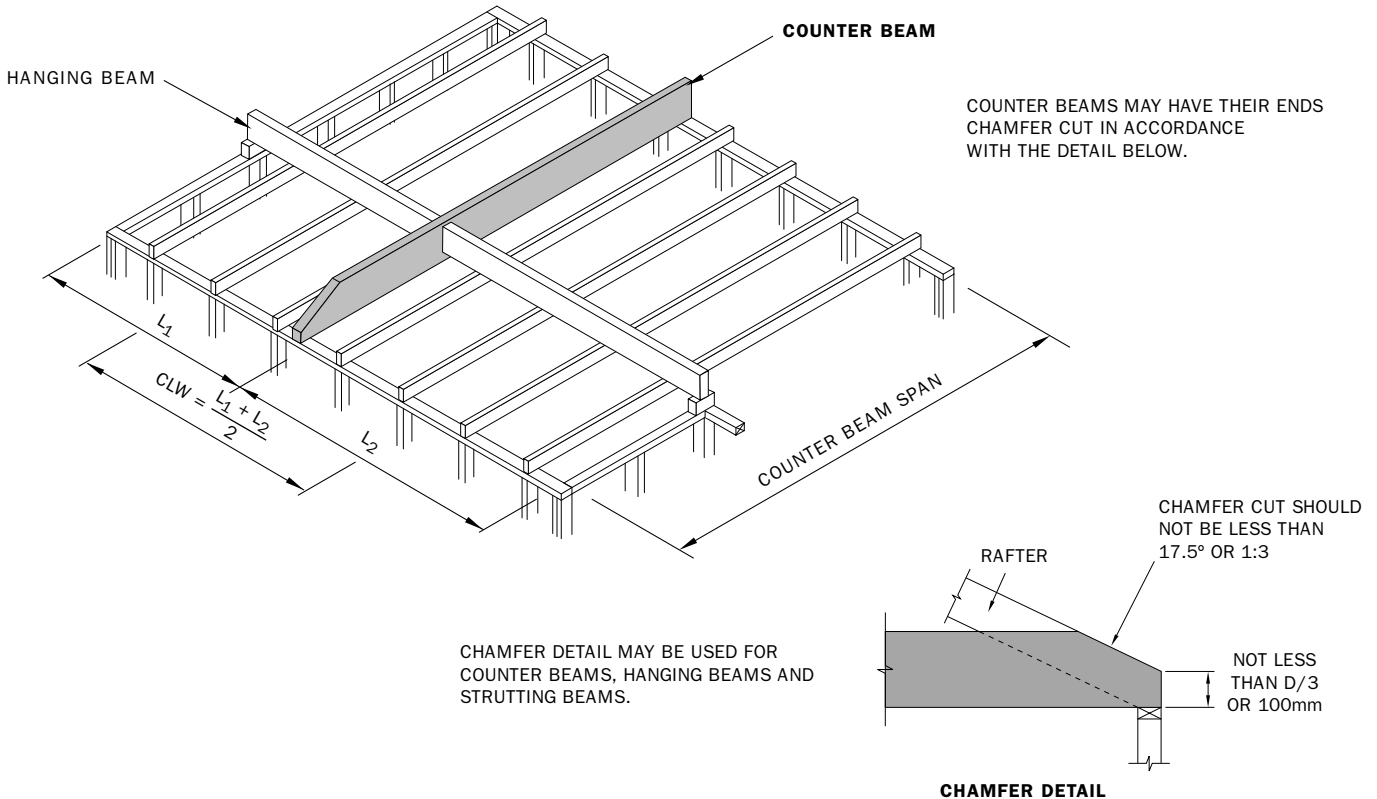



# STRUTTING BEAMS

Supporting Underpurlins

## DETERMINATION OF ROOF LOAD WIDTH 'RLW'.

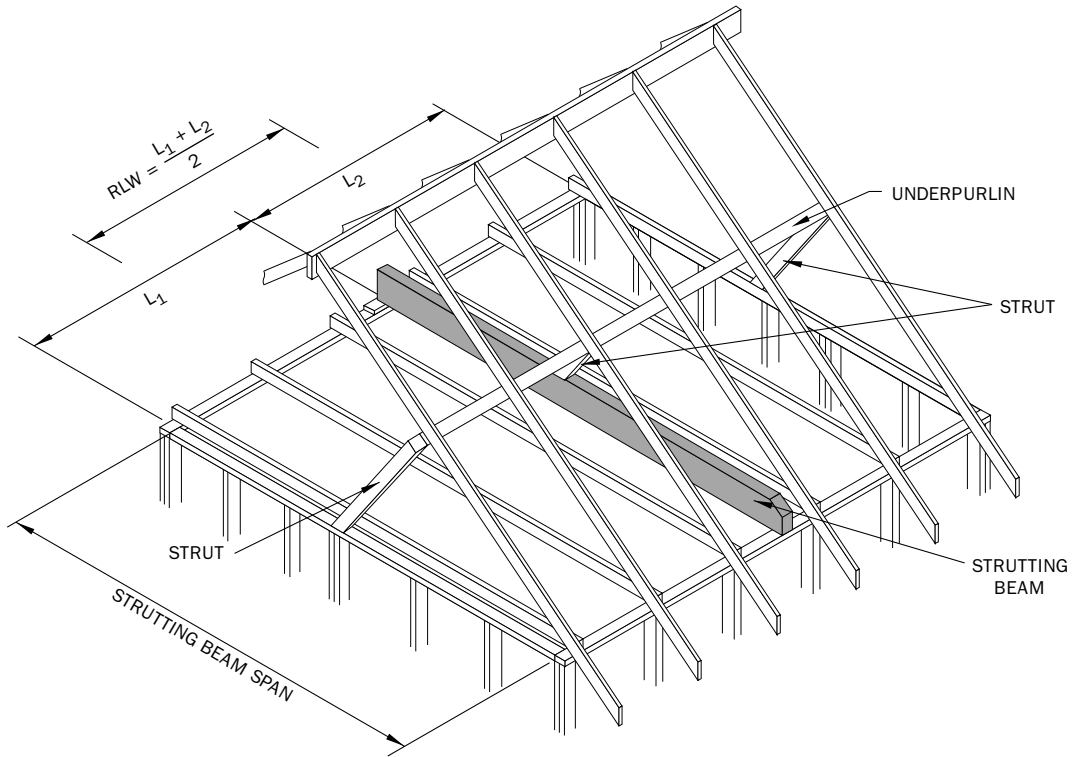

Strutting Beams  
Counter Beams

1. Strutting beams designed to support one or more struts.
2. Strutting beams may be installed in either direction.
3. Ends of strutting beams may be chamfer cut as detailed on page 34.
4. Strutting beams with  $D/B > 3$  should be provided with end restraint as per detail below or similar.
5. Strutting beams with spans shaded in the table should be provided with at least one mid-span restraint see possible detail below. Alternatively restraint may be provided at strutting points.

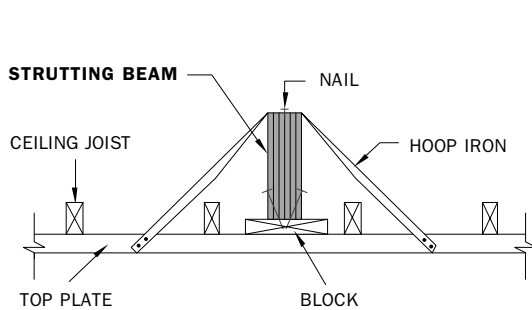

**POSSIBLE END RESTRAINT DETAIL**

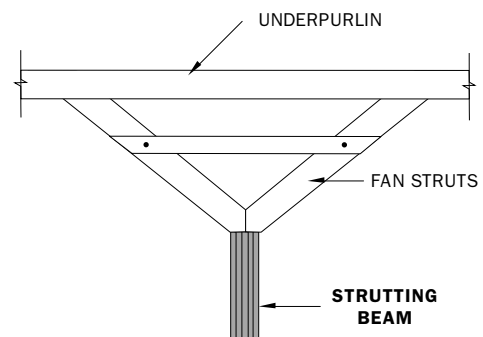

**POSSIBLE INTERMEDIATE RESTRAINT DETAIL**

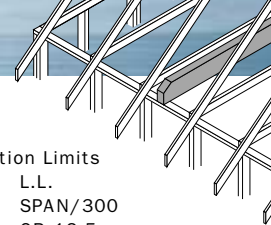

# STRUTTING BEAMS

Supporting Underpurlins

Design Deflection Limits  
 D.L. SPAN/300 OR 20 mm  
 L.L. SPAN/300 OR 12.5 mm

HYSPAN SECTION D X B (mm)	SHEET ROOF												
	ROOF LOAD WIDTH 'RLW' (m) - SEE PAGE 35												
	1.5	1.8	2.1	2.4	2.7	3.0	3.3	3.6	3.9	4.2	4.8	5.4	6.0
MAXIMUM SPAN (m)													
<b>DESIGN WIND SPEED 33 m/s</b>													
150 x 45	4.1	3.9	3.7	3.5	3.4	3.3	3.2	3.1	3.1	3.0	2.9	2.8	2.7
2/150 x 36*	4.7	4.4	4.2	4.1	3.9	3.8	3.7	3.6	3.5	3.5	3.3	3.2	3.1
150 x 63	4.5	4.3	4.1	3.9	3.8	3.7	3.6	3.5	3.4	3.3	3.2	3.1	3.0
150 x 75	4.7	4.5	4.3	4.1	4.0	3.9	3.8	3.7	3.6	3.5	3.4	3.2	3.1
170 x 45	4.6	4.4	4.2	4.0	3.9	3.7	3.6	3.5	3.5	3.4	3.2	3.1	3.0
170 x 63	5.0	4.8	4.6	4.4	4.3	4.1	4.0	3.9	3.8	3.7	3.6	3.5	3.4
200 x 63	5.9	5.6	5.4	5.2	5.0	4.8	4.7	4.6	4.5	4.4	4.2	4.1	3.9
2/200 x 36*	6.1	5.8	5.6	5.4	5.2	5.0	4.9	4.8	4.7	4.6	4.4	4.2	4.1
2/200 x 45*	6.3	6.1	5.9	5.7	5.5	5.4	5.2	5.1	5.0	4.9	4.7	4.5	4.4
240 x 63	6.7	6.5	6.3	6.1	5.9	5.8	5.6	5.5	5.3	5.2	5.0	4.8	4.7
2/240 x 45*	7.1	6.9	6.7	6.6	6.4	6.3	6.2	6.0	5.9	5.8	5.6	5.4	5.2
300 x 63	7.8	7.5	7.3	7.1	7.0	6.8	6.7	6.6	6.5	6.4	6.2	6.0	5.8
300 x 75	8.0	7.8	7.6	7.4	7.2	7.1	6.9	6.8	6.7	6.6	6.4	6.2	6.1
2/300 x 45*	8.3	8.0	7.8	7.6	7.5	7.3	7.2	7.1	7.0	6.9	6.7	6.5	6.4
360 x 63	8.8	8.5	8.3	8.1	7.9	7.8	7.6	7.5	7.4	7.2	7.0	6.9	6.7
400 x 63	9.4	9.2	8.9	8.7	8.5	8.3	8.2	8.0	7.9	7.8	7.6	7.4	7.2
400 x 75	9.7	9.4	9.2	9.0	8.8	8.6	8.5	8.3	8.2	8.1	7.9	7.7	7.5
450 x 63	10.2	9.9	9.7	9.4	9.2	9.1	8.9	8.7	8.6	8.5	8.2	8.0	7.9
<b>DESIGN WIND SPEED 41 m/s</b>													
150 x 45	4.1	3.9	3.7	3.5	3.4	3.3	3.2	3.1	3.1	3.0	2.9	2.8	2.7
2/150 x 36*	4.7	4.4	4.2	4.1	3.9	3.8	3.7	3.6	3.5	3.5	3.3	3.2	3.1
150 x 63	4.5	4.3	4.1	3.9	3.8	3.7	3.6	3.5	3.4	3.3	3.2	3.1	3.0
150 x 75	4.7	4.5	4.3	4.1	4.0	3.9	3.8	3.7	3.6	3.5	3.4	3.2	3.1
170 x 45	4.6	4.4	4.2	4.0	3.9	3.7	3.6	3.5	3.5	3.4	3.2	3.1	3.0
170 x 63	5.0	4.8	4.6	4.4	4.3	4.1	4.0	3.9	3.8	3.7	3.6	3.5	3.4
200 x 63	5.9	5.6	5.4	5.2	5.0	4.8	4.7	4.6	4.5	4.4	4.2	4.1	3.9
2/200 x 36*	6.1	5.8	5.6	5.3	5.1	4.9	4.7	4.6	4.4	4.3	4.1	3.9	3.8
2/200 x 45*	6.3	6.1	5.9	5.7	5.5	5.4	5.2	5.1	5.0	4.9	4.7	4.5	4.4
240 x 63	6.7	6.5	6.3	6.1	5.9	5.8	5.6	5.5	5.3	5.2	5.0	4.8	4.7
2/240 x 45*	7.1	6.9	6.7	6.6	6.4	6.3	6.2	6.0	5.9	5.8	5.5	5.2	5.0
300 x 63	7.8	7.5	7.3	7.1	7.0	6.8	6.7	6.6	6.5	6.4	6.2	5.9	5.7
300 x 75	8.0	7.8	7.6	7.4	7.2	7.1	6.9	6.8	6.7	6.6	6.4	6.2	6.1
2/300 x 45*	8.3	8.0	7.8	7.6	7.4	7.1	6.9	6.7	6.5	6.3	6.0	5.8	5.6
360 x 63	8.8	8.5	8.3	8.1	7.9	7.8	7.6	7.5	7.4	7.2	6.9	6.6	6.3
400 x 63	9.4	9.2	8.9	8.7	8.5	8.3	8.2	8.0	7.9	7.8	7.3	7.0	6.7
400 x 75	9.7	9.4	9.2	9.0	8.8	8.6	8.5	8.3	8.2	8.1	7.9	7.7	7.5
450 x 63	10.2	9.9	9.7	9.4	9.2	9.1	8.8	8.5	8.3	8.1	7.7	7.4	7.1

\* Size built up by vertical nail lamination – see page 5.

For shaded spans, mid-span lateral restraint must be provided

FOR DETERMINATION OF ROOF LOAD WIDTH 'RLW' FOR STRUTTING BEAMS - SEE THE DIAGRAM ON PAGE 35

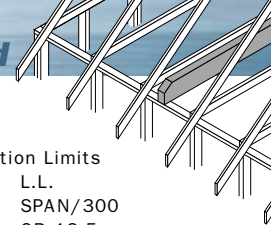

# STRUTTING BEAMS

Supporting Underpurlins

Design Deflection Limits  
 D.L. L.L.  
 SPAN/300 SPAN/300  
 OR 20 mm OR 12.5 mm

HYSPAN SECTION D X B (mm)	TILE ROOF												
	ROOF LOAD WIDTH 'RLW' (m) - SEE PAGE 35												
	1.5	1.8	2.1	2.4	2.7	3.0	3.3	3.6	3.9	4.2	4.8	5.4	6.0
	MAXIMUM SPAN (m)												
150 x 45	2.8	2.6	2.5	2.4	2.3	2.2	2.2	2.1	2.0	2.0	1.9	1.8	1.8
2/150 x 36*	3.2	3.0	2.9	2.8	2.7	2.6	2.5	2.4	2.4	2.3	2.2	2.1	2.1
150 x 63	3.1	2.9	2.8	2.7	2.6	2.5	2.4	2.3	2.3	2.2	2.1	2.0	2.0
150 x 75	3.3	3.1	2.9	2.8	2.7	2.6	2.5	2.5	2.4	2.4	2.3	2.2	2.1
170 x 45	3.1	3.0	2.8	2.7	2.6	2.5	2.4	2.4	2.3	2.3	2.2	2.1	2.0
170 x 63	3.5	3.3	3.1	3.0	2.9	2.8	2.7	2.6	2.6	2.5	2.4	2.3	2.2
200 x 63	4.1	3.9	3.7	3.5	3.4	3.3	3.2	3.1	3.0	3.0	2.8	2.7	2.6
2/200 x 36*	4.3	4.0	3.8	3.7	3.6	3.4	3.3	3.2	3.2	3.1	3.0	2.8	2.7
2/200 x 45*	4.6	4.3	4.1	4.0	3.8	3.7	3.6	3.5	3.4	3.3	3.2	3.1	3.0
240 x 63	4.9	4.6	4.4	4.2	4.1	3.9	3.8	3.7	3.6	3.5	3.4	3.3	3.2
2/240 x 45*	5.4	5.2	4.9	4.7	4.6	4.4	4.3	4.2	4.1	4.0	3.8	3.7	3.5
300 x 63	6.0	5.7	5.5	5.3	5.1	4.9	4.8	4.6	4.5	4.4	4.2	4.1	3.9
300 x 75	6.3	6.0	5.8	5.5	5.4	5.2	5.0	4.9	4.8	4.7	4.5	4.3	4.2
2/300 x 45*	6.5	6.3	6.1	5.9	5.7	5.5	5.3	5.2	5.1	4.9	4.7	4.6	4.4
360 x 63	6.9	6.6	6.4	6.2	6.0	5.9	5.7	5.5	5.4	5.3	5.1	4.9	4.7
400 x 63	7.4	7.2	6.9	6.7	6.5	6.4	6.2	6.1	6.0	5.9	5.6	5.4	5.2
400 x 75	7.7	7.4	7.2	7.0	6.8	6.6	6.5	6.4	6.2	6.1	5.9	5.7	5.5
450 x 63	8.1	7.8	7.5	7.3	7.1	6.9	6.8	6.7	6.5	6.4	6.2	6.1	5.9

\* Size built up by vertical nail lamination – see page 5. For shaded spans midspan lateral restraint must be provided - see page 35.

FOR DETERMINATION OF ROOF LOAD WIDTH 'RLW' FOR STRUTTING BEAMS - SEE THE DIAGRAM ON PAGE 35.

Strutting Beams

# STRUTTING BEAMS

Supporting Underpurlins and Ceiling Joists

## DETERMINATION OF ROOF LOAD WIDTH 'RLW'.

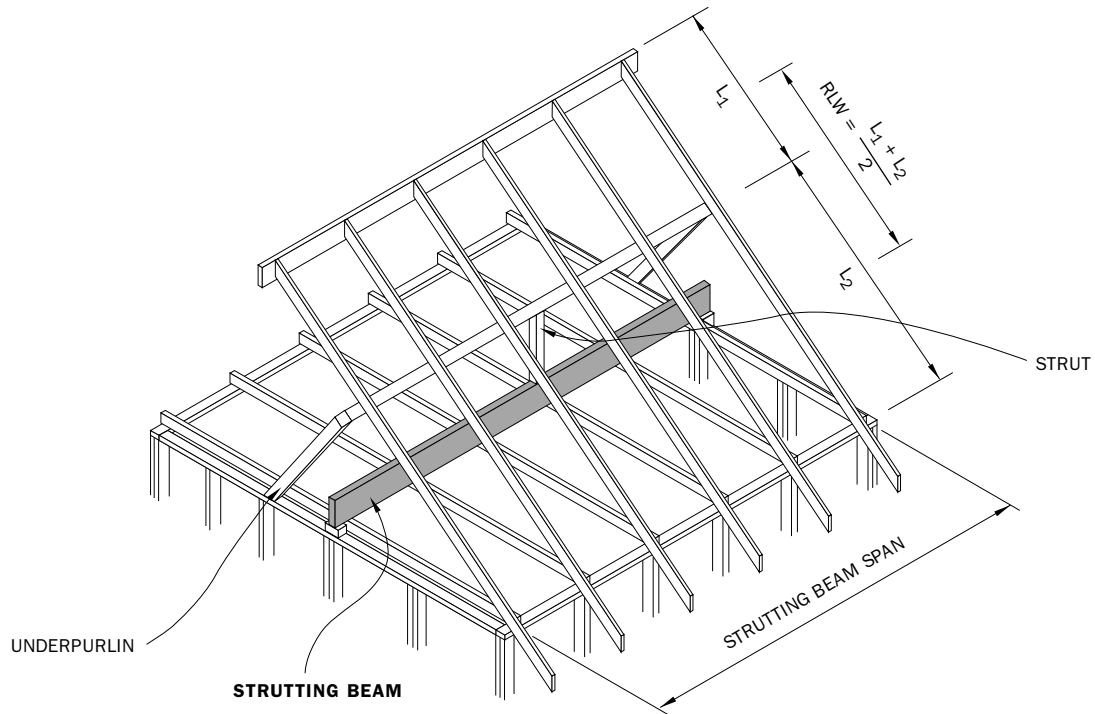

1. Strutting beams designed to support one or more struts.
2. Ends of strutting beams may be chamfer cut as detailed on page 34.
3. Strutting beams with  $D/B > 3$  should be provided with end restraint as per detail below or similar.
4. Strutting beams with spans shaded in the table should be provided with at least one mid-span restraint - see possible detail below. Alternatively restraint may be provided at strutting points.

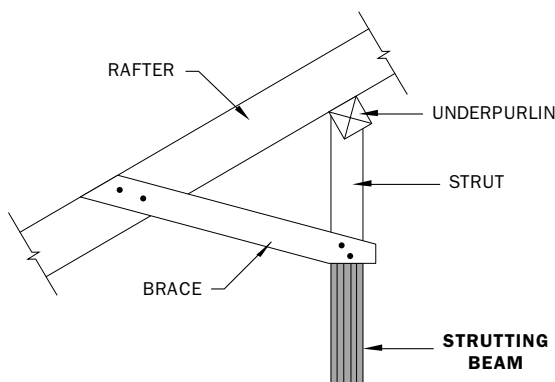

POSSIBLE INTERMEDIATE RESTRAINT DETAIL

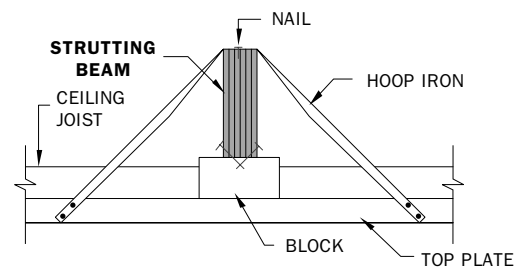

POSSIBLE END RESTRAINT DETAIL



# STRUTTING BEAMS

Supporting Underpurlins and Ceiling Joists

Design Deflection Limits  
 D.L. L.L.  
 SPAN/300 SPAN/300  
 OR 12.5 mm OR 12.5 mm

HYSPAN SECTION D X B (mm)	SHEET ROOF AND CEILING												
	ROOF LOAD WIDTH 'RLW' (m)												
	1.5	1.8	2.1	2.4	2.7	3.0	3.3	3.6	3.9	4.2	4.8	5.4	6.0
	MAXIMUM SPAN (m)												
2/170 x 45*	4.3	4.2	4.0	3.9	3.8	3.7	3.6	3.5	3.4	3.3	3.2	3.1	3.0
170 x 63	4.0	3.8	3.7	3.5	3.4	3.3	3.2	3.1	3.0	3.0	2.8	2.7	2.6
2/170 x 36*	4.1	4.0	3.8	3.7	3.6	3.4	3.3	3.2	3.2	3.1	3.0	2.9	2.8
200 x 63	4.5	4.3	4.2	4.0	3.9	3.8	3.8	3.7	3.6	3.5	3.3	3.2	3.1
2/200 x 36*	4.6	4.4	4.3	4.2	4.1	4.0	3.9	3.8	3.7	3.6	3.5	3.4	3.2
2/200 x 45*	4.9	4.7	4.5	4.4	4.3	4.2	4.1	4.0	3.9	3.9	3.7	3.6	3.5
240 x 63	5.1	4.9	4.8	4.6	4.5	4.4	4.3	4.2	4.1	4.1	3.9	3.8	3.7
2/240 x 45*	5.5	5.3	5.1	5.0	4.9	4.8	4.7	4.6	4.5	4.4	4.3	4.2	4.1
300 x 63	6.0	5.8	5.6	5.4	5.3	5.2	5.1	5.0	4.9	4.8	4.6	4.5	4.4
300 x 75	6.2	6.0	5.8	5.6	5.5	5.4	5.3	5.2	5.1	5.0	4.8	4.7	4.6
2/300 x 45*	6.5	6.2	6.0	5.9	5.7	5.6	5.5	5.4	5.3	5.2	5.0	4.9	4.8
360 x 63	6.8	6.6	6.4	6.2	6.0	5.9	5.8	5.7	5.6	5.5	5.3	5.2	5.0
400 x 63	7.4	7.1	6.9	6.7	6.5	6.4	6.2	6.1	6.0	5.9	5.7	5.6	5.4
400 x 75	7.6	7.3	7.1	6.9	6.8	6.6	6.5	6.3	6.2	6.1	6.0	5.8	5.7
2/400 x 45*	7.9	7.6	7.4	7.2	7.0	6.9	6.7	6.6	6.5	6.4	6.2	6.0	5.9
450 x 63	8.0	7.7	7.5	7.3	7.1	6.9	6.8	6.6	6.5	6.4	6.2	6.1	5.9
2/450 x 63*	9.0	8.7	8.5	8.3	8.1	8.0	7.8	7.7	7.6	7.5	7.3	7.1	6.9
	TILE ROOF AND CEILING												
170 x 63	3.2	3.0	2.9	2.8	2.7	2.6	2.5	2.4	2.4	2.3	2.2	2.1	2.0
2/170 x 36*	3.3	3.2	3.0	2.9	2.8	2.7	2.6	2.5	2.5	2.4	2.3	2.2	2.1
2/170 x 45*	3.6	3.4	3.2	3.1	3.0	2.9	2.8	2.7	2.6	2.6	2.5	2.4	2.3
200 x 63	3.8	3.6	3.4	3.2	3.1	3.0	2.9	2.8	2.8	2.7	2.6	2.5	2.4
2/200 x 36*	3.9	3.7	3.5	3.4	3.3	3.1	3.1	3.0	2.9	2.8	2.7	2.6	2.5
2/200 x 45*	4.1	3.9	3.8	3.6	3.5	3.4	3.3	3.2	3.1	3.0	2.9	2.8	2.7
240 x 63	4.3	4.1	4.0	3.8	3.7	3.6	3.5	3.4	3.3	3.2	3.1	3.0	2.9
2/240 x 45*	4.7	4.5	4.3	4.2	4.1	4.0	3.9	3.8	3.7	3.6	3.5	3.4	3.2
300 x 63	5.1	4.8	4.7	4.5	4.4	4.3	4.2	4.1	4.0	4.0	3.8	3.7	3.6
300 x 75	5.3	5.0	4.9	4.7	4.6	4.5	4.4	4.3	4.2	4.1	4.0	3.9	3.8
2/300 x 45*	5.5	5.3	5.1	4.9	4.8	4.7	4.6	4.5	4.4	4.3	4.2	4.1	4.0
360 x 63	5.8	5.5	5.3	5.2	5.0	4.9	4.8	4.7	4.6	4.5	4.4	4.3	4.2
400 x 63	6.2	6.0	5.8	5.6	5.4	5.3	5.2	5.1	5.0	4.9	4.8	4.6	4.5
400 x 75	6.5	6.2	6.0	5.8	5.7	5.5	5.4	5.3	5.2	5.1	5.0	4.8	4.7
2/400 x 45*	6.7	6.5	6.3	6.1	5.9	5.8	5.6	5.5	5.4	5.3	5.2	5.0	4.9
450 x 63	6.8	6.5	6.3	6.1	5.9	5.8	5.7	5.6	5.4	5.4	5.2	5.0	4.9
2/450 x 63*	7.8	7.6	7.3	7.1	6.9	6.8	6.6	6.5	6.4	6.3	6.1	5.9	5.8

\* Sizes built up by vertical nail lamination - see page 5. For shaded spans midspan lateral restraint must be provided - see page 38.

FOR DETERMINATION OF ROOF LOAD WIDTH 'RLW' FOR STRUTTING BEAMS - SEE THE DIAGRAM ON PAGE 38.

# STRUTTING BEAMS

*Supporting Underpurlins and Hanging Beams*

## DETERMINATION OF ROOF LOAD WIDTH 'RLW'.

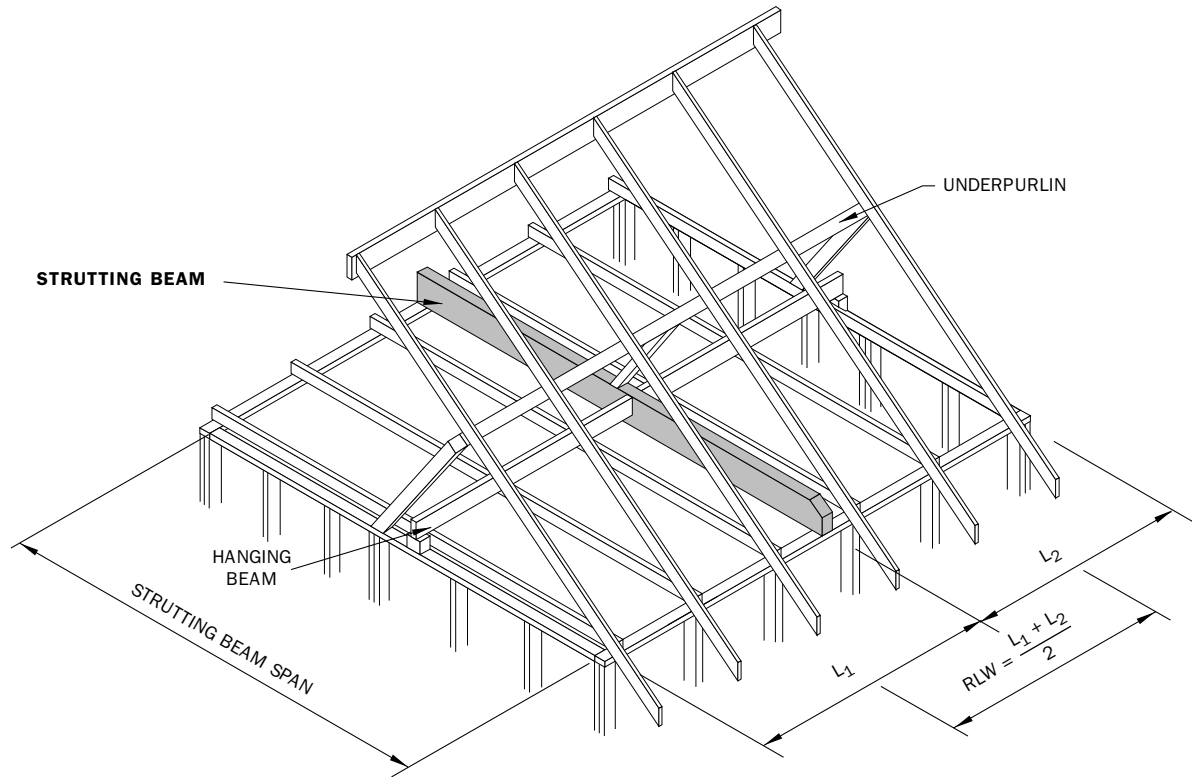

1. Strutting beams designed to support one or more struts.
2. Ends of strutting beams may be chamfer cut as detailed on page 34.
3. Strutting beams with  $D/B > 3$  should be provided with end restraint as per detail on page 35 or similar.
4. It has been assumed that hanging beams provide intermediate lateral restraint.





# STRUTTING BEAMS

Supporting Underpurlins and Hanging Beams

Design Deflection Limits  
 D.L. L.L.  
 SPAN/300 SPAN/300  
 OR 12.5 mm OR 12.5 mm

HYSPAN SECTION D X B (mm)	SHEET ROOF AND CEILING												
	ROOF LOAD WIDTH 'RLW' (m)												
	1.5	1.8	2.1	2.4	2.7	3.0	3.3	3.6	3.9	4.2	4.8	5.4	6.0
	MAXIMUM SPAN (m)												
170 x 63	4.0	3.9	3.7	3.7	3.6	3.5	3.4	3.3	3.2	3.1	3.0	2.9	2.8
2/170 x 36	4.2	4.0	3.9	3.7	3.6	3.6	3.5	3.4	3.3	3.3	3.1	3.0	2.9
2/170 x 45	4.4	4.2	4.1	3.9	3.8	3.7	3.6	3.6	3.6	3.5	3.4	3.2	3.1
200 x 63	4.5	4.4	4.2	4.1	4.0	3.9	3.8	3.7	3.6	3.7	3.5	3.4	3.3
2/200 x 36*	4.7	4.5	4.3	4.2	4.1	4.0	3.9	3.8	3.8	3.7	3.7	3.5	3.4
2/200 x 45*	4.9	4.7	4.6	4.4	4.3	4.2	4.1	4.0	4.0	3.9	3.8	3.7	3.7
240 x 63	5.2	5.0	4.8	4.7	4.5	4.4	4.3	4.3	4.2	4.1	4.0	3.9	3.8
2/240 x 45*	5.6	5.4	5.2	5.0	4.9	4.8	4.7	4.6	4.5	4.5	4.3	4.2	4.1
300 x 63	6.1	5.8	5.6	5.5	5.3	5.2	5.1	5.0	4.9	4.8	4.7	4.6	4.4
300 x 75	6.3	6.0	5.9	5.7	5.5	5.4	5.3	5.2	5.1	5.0	4.9	4.7	4.6
2/300 x 45*	6.5	6.3	6.1	5.9	5.8	5.6	5.5	5.4	5.3	5.2	5.1	4.9	4.8
360 x 63	6.9	6.6	6.4	6.2	6.1	5.9	5.8	5.7	5.6	5.5	5.3	5.2	5.1
400 x 63	7.3	7.1	6.9	6.7	6.6	6.4	6.3	6.2	6.1	6.0	5.8	5.6	5.5
400 x 75	7.6	7.3	7.2	7.0	6.8	6.7	6.5	6.4	6.3	6.2	6.0	5.9	5.7
2/400 x 45*	7.8	7.6	7.4	7.2	7.1	6.9	6.8	6.7	6.5	6.4	6.3	6.1	6.0
450 x 63	8.0	7.7	7.5	7.3	7.1	7.0	6.8	6.7	6.6	6.5	6.3	6.1	6.0
2/450 x 63	9.0	8.7	8.5	8.3	8.1	8.0	7.8	7.7	7.6	7.5	7.3	7.1	7.0
	TILE ROOF AND CEILING												
170 x 63	3.4	3.2	3.0	2.9	2.8	2.7	2.6	2.5	2.5	2.4	2.3	2.2	2.1
2/170 x 36	3.5	3.3	3.2	3.0	2.9	2.8	2.7	2.7	2.6	2.5	2.4	2.3	2.2
2/170 x 45	3.6	3.5	3.4	3.2	3.1	3.0	2.9	2.8	2.8	2.7	2.6	2.5	2.4
200 x 63	3.8	3.7	3.5	3.4	3.3	3.2	3.1	3.0	2.9	2.8	2.7	2.6	2.5
2/200 x 36*	3.9	3.7	3.7	3.5	3.4	3.3	3.2	3.1	3.0	3.0	2.8	2.7	2.6
2/200 x 45*	4.1	3.9	3.8	3.7	3.7	3.5	3.4	3.3	3.3	3.2	3.1	2.9	2.8
240 x 63	4.3	4.1	4.0	3.9	3.8	3.6	3.7	3.6	3.5	3.4	3.3	3.1	3.0
2/240 x 45*	4.7	4.5	4.3	4.2	4.1	4.0	3.9	3.8	3.7	3.7	3.7	3.5	3.4
300 x 63	5.1	4.9	4.7	4.6	4.4	4.3	4.2	4.1	4.1	4.0	3.9	3.7	3.6
300 x 75	5.3	5.1	4.9	4.7	4.6	4.5	4.4	4.3	4.2	4.2	4.0	3.9	3.8
2/300 x 45*	5.5	5.3	5.1	4.9	4.8	4.7	4.6	4.5	4.4	4.3	4.2	4.1	4.0
360 x 63	5.8	5.6	5.4	5.2	5.1	4.9	4.8	4.7	4.6	4.6	4.4	4.3	4.2
400 x 63	6.3	6.0	5.8	5.6	5.5	5.3	5.2	5.1	5.0	4.9	4.8	4.6	4.5
400 x 75	6.5	6.2	6.0	5.9	5.7	5.6	5.4	5.3	5.2	5.1	5.0	4.8	4.7
2/400 x 45*	6.8	6.5	6.3	6.1	5.9	5.8	5.7	5.6	5.5	5.4	5.1	4.8	4.6
450 x 63	6.8	6.5	6.3	6.1	6.0	5.8	5.7	5.6	5.5	5.4	5.2	5.1	4.9
2/450 x 63	7.8	7.5	7.3	7.1	7.0	6.8	6.7	6.5	6.4	6.3	6.1	6.0	5.8

\* Sizes built up by vertical nail lamination - see page 5

FOR DETERMINATION OF ROOF LOAD WIDTH 'RLW' FOR STRUTTING BEAMS - SEE THE DIAGRAM ON PAGE 40.

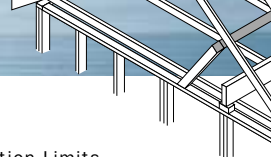

# UNDERPURLINS

Design Deflection Limits  
 D.L. L.L.  
 SPAN/300 SPAN/300  
 OR 20 mm OR 12.5 mm

HYPAN SECTION D X B (mm)	ROOF TYPE	DESIGN WIND SPEED (m/s)	SINGLE SPAN				CONTINUOUS SPAN			
			ROOF LOAD WIDTH 'RLW' (m)							
			1.8	2.4	2.7	3.6	1.8	2.4	2.7	3.6
MAXIMUM SPAN (m)										
95 x 63	SHEET	33	2.5	2.3	2.2	2.0	3.0	2.8	2.7	2.5
	SHEET	41	2.5	2.3	2.2	2.0	3.0	2.6	2.4	2.1
	TILE	41	1.8	1.6	1.6	1.4	2.3	2.0	1.9	1.7
130 x 63	SHEET	33	3.4	3.1	3.0	2.7	4.2	3.9	3.7	3.3
	SHEET	41	3.4	3.1	3.0	2.7	4.1	3.5	3.3	2.9
	TILE	41	2.5	2.2	2.1	1.9	3.1	2.7	2.6	2.4
150 x 63	SHEET	33	3.9	3.6	3.4	3.1	4.9	4.4	4.3	3.8
	SHEET	41	3.9	3.6	3.4	3.1	4.7	4.1	3.8	3.3
	TILE	41	2.9	2.6	2.5	2.2	3.5	3.2	3.0	2.7
150 x 75	SHEET	33	4.1	3.8	3.6	3.3	5.1	4.7	4.5	4.1
	SHEET	41	4.1	3.8	3.6	3.3	5.1	4.4	4.2	3.6
	TILE	41	3.0	2.7	2.6	2.3	3.7	3.3	3.2	2.9
170 x 63	SHEET	33	4.4	4.1	3.9	3.5	5.5	5.0	4.8	4.3
	SHEET	41	4.4	4.1	3.9	3.5	5.3	4.6	4.3	3.8
	TILE	41	3.2	2.9	2.8	2.5	4.0	3.6	3.5	3.1
200 x 63	SHEET	33	5.2	4.7	4.6	4.1	6.3	5.9	5.6	5.1
	SHEET	41	5.2	4.7	4.6	4.1	6.3	5.4	5.1	4.4
	TILE	41	3.8	3.4	3.3	3.0	4.7	4.2	4.1	3.6
240 x 63	SHEET	33	6.1	5.6	5.4	4.9	7.2	6.7	6.5	6.1
	SHEET	41	6.1	5.6	5.4	4.9	7.2	6.5	6.1	5.3
	TILE	41	4.5	4.1	3.9	3.5	5.6	5.0	4.8	4.4
300 x 63	SHEET	33	7.2	6.7	6.5	6.1	8.4	7.9	7.7	7.1
	SHEET	41	7.2	6.7	6.5	6.1	8.4	7.9	7.5	6.5
	TILE	41	5.6	5.1	4.9	4.4	6.7	6.2	6.0	5.4
300 x 75	SHEET	33	7.4	7.0	6.8	6.3	-	8.2	7.9	7.4
	SHEET	41	7.4	7.0	6.8	6.3	-	8.2	7.9	7.3
	TILE	41	5.9	5.3	5.2	4.7	7.0	6.5	6.3	5.7

FOR DETERMINATION OF ROOF LOAD WIDTH 'RLW' FOR UNDERPURLINS - SEE THE DIAGRAM BELOW.

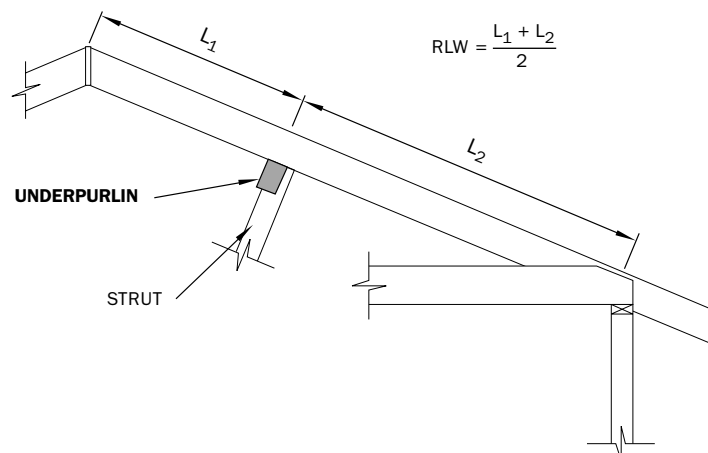

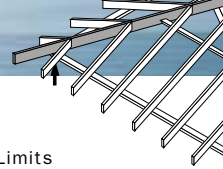

Design Deflection Limits  
 D.L. L.L.  
 SPAN/300 SPAN/300  
 OR 20 mm OR 12.5 mm

# HIP OR VALLEY RAFTERS

Supporting Underpurlins and Rafters

HYSPAN SECTION D X B (mm)	SHEET ROOF	TILE ROOF
	MAXIMUM HIP RAFTER SPAN (m)	
130 x 36	3.2	2.5
130 x 45	3.4	2.6
150 x 36	3.6	2.7
150 x 45	3.7	2.9
150 x 75	4.2	3.3
170 x 36	3.9	3.0
170 x 45	4.1	3.2
200 x 36	4.4	3.4
200 x 45	4.6	3.6
240 x 45	5.3	4.1
240 x 63	5.7	4.4
300 x 45	6.2	4.8
300 x 63	6.6	5.2
300 x 75	6.8	5.5
360 x 63	7.3	6.0
400 x 45	7.0	6.0
400 x 63	7.8	6.4
400 x 75	8.0	6.6
450 x 63	8.4	6.9
525 x 75	9.4	7.8

Underpurlins  
Hip or Valley  
Rafter

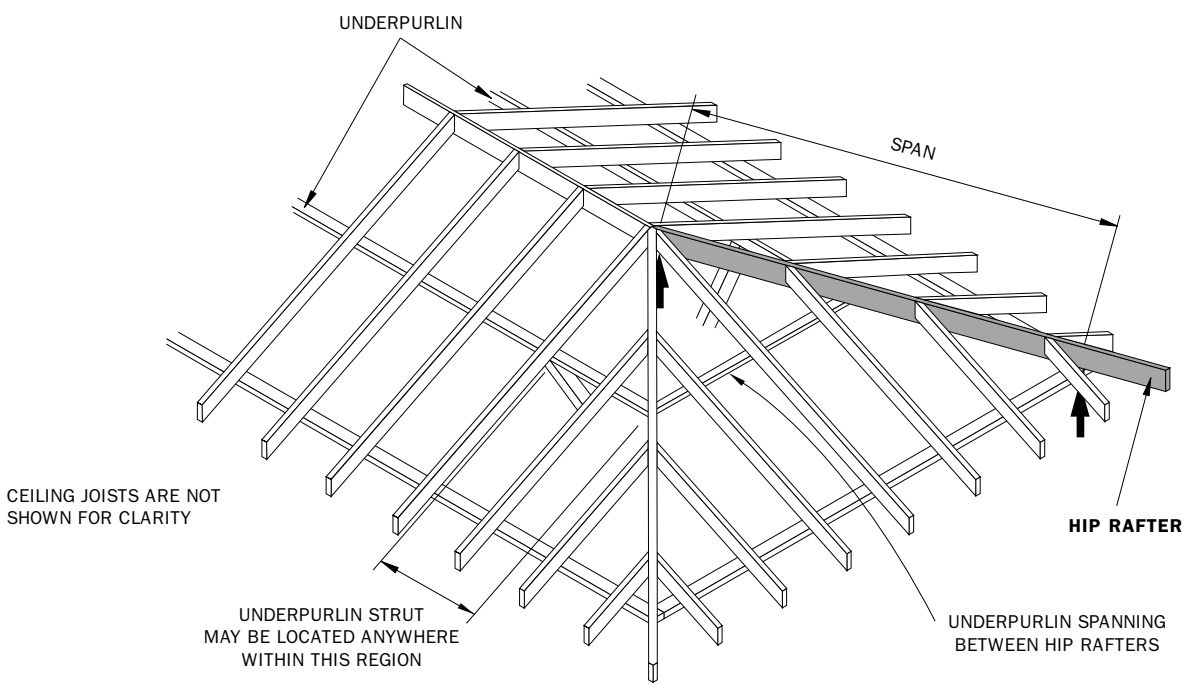

# HIP OR VALLEY RAFTERS

*Supporting Rafters only*

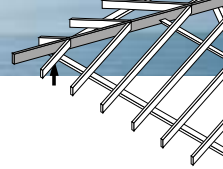

## SINGLE SPAN HIP RAFTER

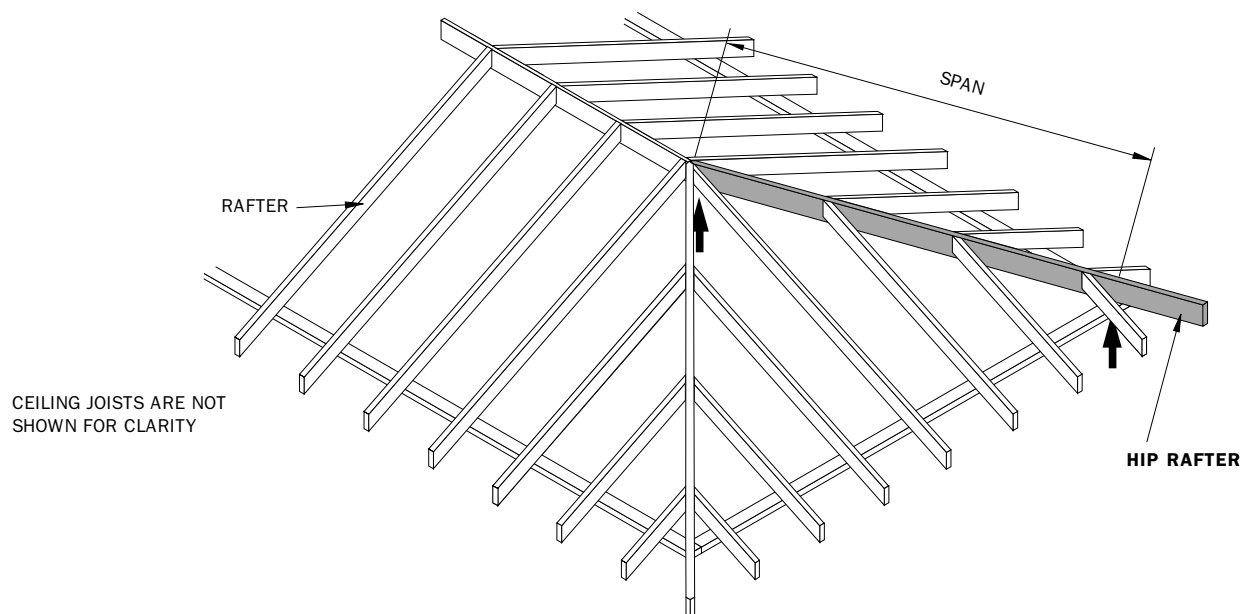

## CONTINUOUS SPAN HIP RAFTER

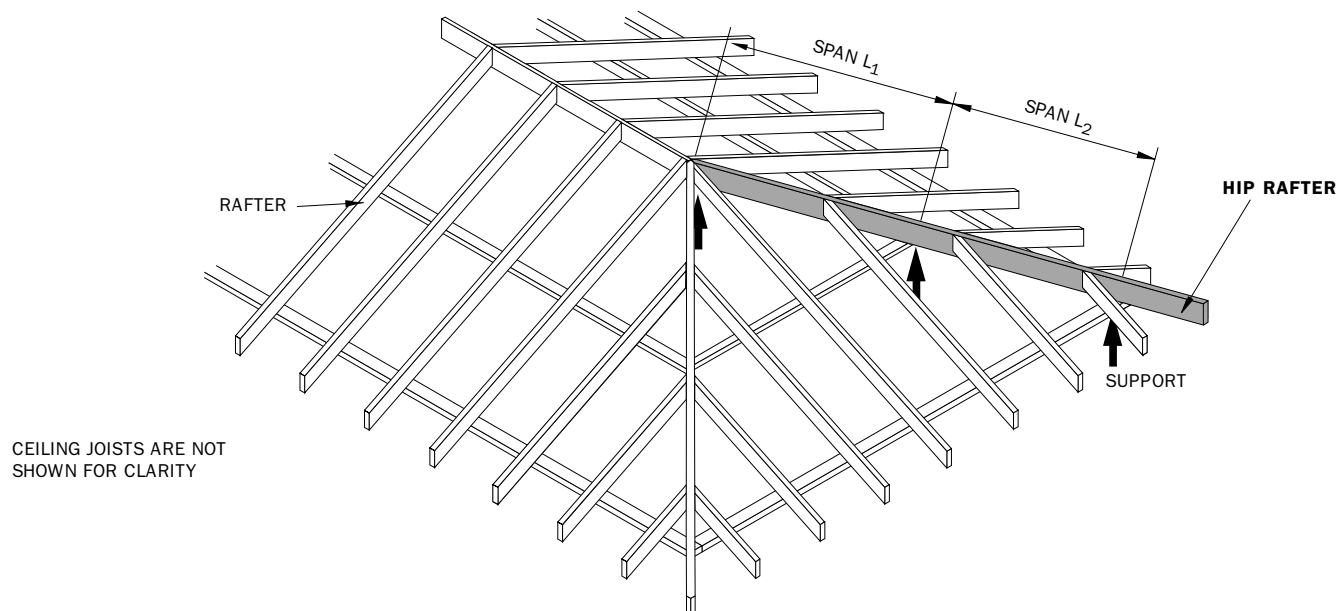

### Note

1. Use the largest span ( $L_1$  or  $L_2$ ) to enter the table.
2. The largest span should not be greater than twice the adjacent span otherwise use the single span table.

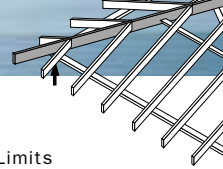

# HIP OR VALLEY RAFTERS

*Supporting Rafters only*

Design Deflection Limits  
 D.L. L.L.  
 SPAN/300 SPAN/300  
 OR 20 mm OR 12.5 mm

HYSPAN SECTION D X B (mm)	SHEET ROOF ONLY	SHEET ROOF AND CEILING	TILE ROOF ONLY	TILE ROOF AND CEILING
	MAXIMUM SINGLE SPAN (m)			
130 x 36	3.2	3.0	2.6	2.5
130 x 45	3.5	3.1	2.7	2.6
150 x 36	3.7	3.3	2.9	2.7
150 x 45	3.9	3.5	3.0	2.9
150 x 75	4.4	3.9	3.4	3.3
170 x 36	4.1	3.6	3.1	3.0
170 x 45	4.3	3.8	3.3	3.2
200 x 36	4.6	4.1	3.5	3.4
200 x 45	4.8	4.3	3.7	3.6
240 x 45	5.5	5.0	4.3	4.1
240 x 63	5.9	5.4	4.6	4.4
300 x 45	6.4	5.9	5.1	4.8
300 x 63	6.8	6.2	5.5	5.2
300 x 75	7.0	6.4	5.7	5.5
360 x 63	7.5	7.0	6.2	6.0
400 x 63	8.0	7.4	6.6	6.4
400 x 75	8.3	7.6	6.8	6.6
450 x 63	8.6	7.9	7.1	6.8
	MAXIMUM CONTINUOUS SPAN (m)			
130 x 36	3.9	3.5	3.0	2.9
130 x 45	4.1	3.7	3.2	3.0
150 x 36	4.4	3.9	3.4	3.2
150 x 45	4.6	4.1	3.5	3.4
150 x 75	5.1	4.6	4.0	3.8
170 x 36	4.8	4.3	3.7	3.5
170 x 45	5.0	4.5	3.9	3.7
200 x 36	5.4	4.8	4.2	4.0
200 x 45	5.7	5.1	4.4	4.2
240 x 45	6.4	5.8	5.0	4.8
240 x 63	6.8	6.2	5.4	5.2
300 x 45	7.3	6.7	5.9	5.7
300 x 63	7.7	7.1	6.3	6.1
300 x 75	8.0	7.3	6.5	6.3
360 x 63	-	7.9	7.1	6.8
400 x 63	-	-	7.5	7.3
400 x 75	-	-	7.8	7.5
450 x 63	-	-	-	7.8

Hip rafter tables prepared for rectangular plans. The tables may be conservatively applied for more closely spaced hips as may occur with hexagonal or octagonal plans.

# RAFTERS

## DIAGRAMS FOR INTERPRETATION OF RAFTER TABLES

### Single Span Rafter

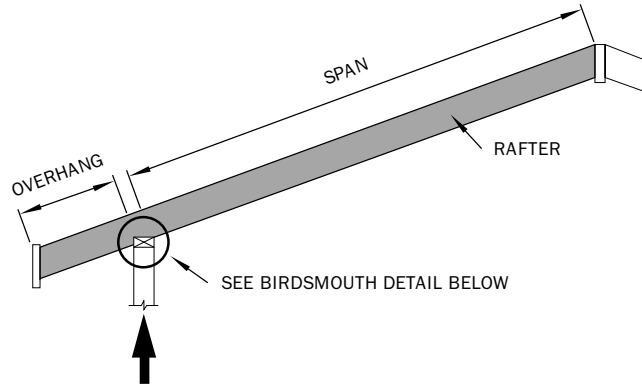

### Continuous Span Rafter

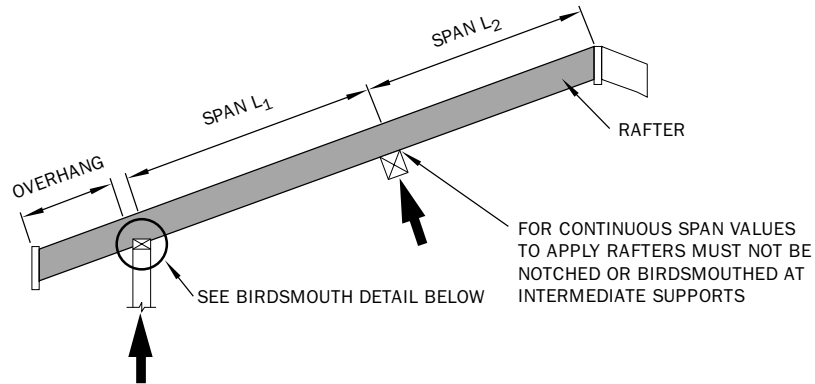

The largest span of  $L_1$  and  $L_2$  should be selected for entering the table, however the largest span should not be greater than twice the adjacent span otherwise use the single span table.

### Overhangs

The maximum overhangs given in rafter tables 22 and 23 only apply where the birdsmouth does not exceed  $D/3$  as shown below.

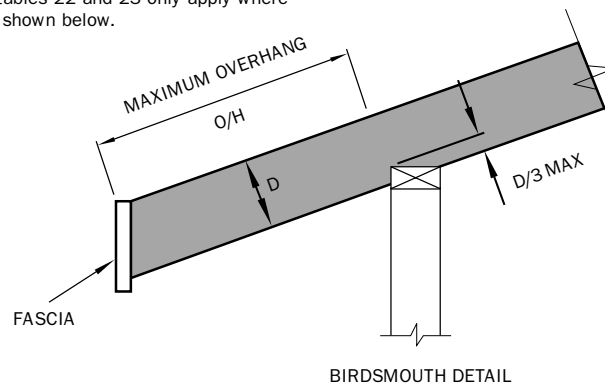



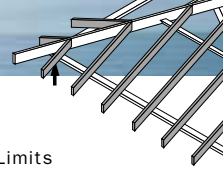

# RAFTERS

Design Wind Speed 33 m/s

Design Deflection Limits  
 D.L. L.L.  
 SPAN/300 SPAN/300  
 OR 20 mm OR 12.5 mm

HYSPAN SECTION D X B (mm)	ROOF MASS kg/m <sup>2</sup>	SINGLE SPAN								CONTINUOUS SPAN									
		MAXIMUM RAFTER SPACING (mm)																	
		450		600		900		1200		450		600		900		1200			
		MAXIMUM RAFTER SPAN AND OVERHANG 'O/H' (m)																	
SPAN		O/H		SPAN		O/H		SPAN		O/H		SPAN		O/H		SPAN		O/H	
95 x 36	10	2.9	0.8	2.8	0.8	2.6	0.6	2.4	0.5	3.9	0.7	3.8	0.7	3.5	0.6	3.2	0.5		
	20	2.9	0.8	2.8	0.8	2.6	0.7	2.4	0.5	3.9	0.7	3.8	0.7	3.4	0.6	3.2	0.5		
	30	2.9	0.8	2.8	0.8	2.5	0.7	2.3	0.6	3.7	0.7	3.4	0.7	3.0	0.7	2.8	0.6		
	40	2.8	0.9	2.6	0.8	2.3	0.7	2.1	0.6	3.4	0.8	3.2	0.7	2.8	0.7	2.5	0.6		
	60	2.5	0.9	2.3	0.9	2.0	0.7	1.8	0.6	3.0	0.8	2.8	0.8	2.4	0.7	2.2	0.6		
	75	2.3	1.0	2.1	0.9	1.8	0.8	1.7	0.6	2.8	0.9	2.6	0.8	2.3	0.8	2.1	0.6		
	90	2.2	1.0	2.0	0.9	1.7	0.8	1.6	0.7	2.7	0.9	2.4	0.8	2.1	0.8	2.0	0.7		
95 x 45	10	3.2	0.9	3.1	0.8	2.9	0.7	2.7	0.6	4.2	0.8	4.0	0.7	3.8	0.7	3.6	0.6		
	20	3.2	0.9	3.1	0.8	2.9	0.7	2.7	0.6	4.2	0.8	4.0	0.7	3.7	0.7	3.4	0.6		
	30	3.2	0.9	3.0	0.8	2.6	0.8	2.4	0.6	4.0	0.8	3.7	0.8	3.3	0.7	3.0	0.6		
	40	3.0	0.9	2.7	0.9	2.4	0.8	2.2	0.7	3.7	0.8	3.4	0.8	3.0	0.7	2.7	0.7		
	60	2.6	1.0	2.4	0.9	2.1	0.8	1.9	0.7	3.3	0.9	3.0	0.8	2.6	0.8	2.4	0.7		
	75	2.5	1.0	2.3	0.9	2.0	0.9	1.8	0.7	3.0	0.9	2.8	0.9	2.4	0.8	2.2	0.7		
	90	2.3	1.1	2.1	1.0	1.9	0.9	1.7	0.8	2.9	1.0	2.6	0.9	2.3	0.8	2.1	0.8		
130 x 36	10	4.3	1.1	4.1	1.0	3.9	0.8	3.7	0.7	5.2	1.0	5.1	0.9	4.8	0.8	4.5	0.7		
	20	4.3	1.1	4.1	1.0	3.8	0.9	3.5	0.7	5.2	1.0	5.1	0.9	4.6	0.8	4.3	0.7		
	30	4.1	1.1	3.8	1.0	3.3	0.9	3.1	0.7	5.0	1.0	4.6	0.9	4.1	0.9	3.8	0.7		
	40	3.8	1.2	3.5	1.1	3.1	0.9	2.8	0.7	4.6	1.0	4.3	1.0	3.8	0.9	3.5	0.7		
	60	3.3	1.2	3.1	1.1	2.7	1.0	2.5	0.8	4.1	1.1	3.8	1.0	3.3	1.0	3.0	0.8		
	75	3.1	1.3	2.9	1.2	2.5	1.0	2.3	0.8	3.9	1.1	3.5	1.1	3.1	1.0	2.8	0.8		
	90	2.9	1.3	2.7	1.2	2.4	1.1	2.2	0.9	3.6	1.2	3.3	1.1	2.9	1.0	2.7	0.9		
130 x 45	10	4.6	1.2	4.4	1.1	4.2	0.9	4.0	0.8	5.6	1.0	5.4	1.0	5.1	0.9	4.9	0.8		
	20	4.6	1.2	4.4	1.1	4.0	1.0	3.7	0.8	5.6	1.0	5.4	1.0	5.0	0.9	4.6	0.8		
	30	4.3	1.2	4.0	1.1	3.6	1.0	3.3	0.8	5.4	1.1	5.0	1.0	4.4	1.0	4.0	0.8		
	40	4.0	1.3	3.7	1.2	3.3	1.0	3.0	0.8	5.0	1.1	4.6	1.1	4.0	1.0	3.7	0.8		
	60	3.6	1.3	3.3	1.2	2.9	1.1	2.6	0.9	4.4	1.2	4.0	1.1	3.6	1.1	3.3	0.9		
	75	3.3	1.4	3.1	1.3	2.7	1.1	2.5	0.9	4.1	1.2	3.8	1.2	3.3	1.1	3.0	0.9		
	90	3.2	1.4	2.9	1.3	2.5	1.2	2.3	1.0	3.9	1.3	3.6	1.2	3.1	1.1	2.9	1.0		
150 x 36	10	4.9	1.2	4.7	1.1	4.5	0.9	4.3	0.8	6.0	1.1	5.8	1.0	5.5	0.9	5.2	0.8		
	20	4.9	1.2	4.7	1.1	4.3	1.0	4.0	0.8	6.0	1.1	5.8	1.0	5.3	0.9	4.9	0.8		
	30	4.7	1.3	4.3	1.2	3.8	1.0	3.5	0.8	5.8	1.1	5.3	1.1	4.7	1.0	4.3	0.8		
	40	4.3	1.3	4.0	1.2	3.5	1.0	3.2	0.8	5.3	1.2	4.9	1.1	4.3	1.0	4.0	0.8		
	60	3.8	1.4	3.5	1.3	3.1	1.1	2.8	0.9	4.7	1.3	4.3	1.2	3.8	1.1	3.5	0.9		
	75	3.6	1.5	3.3	1.4	2.9	1.1	2.6	0.9	4.4	1.3	4.1	1.2	3.6	1.1	3.3	0.9		
	90	3.4	1.5	3.1	1.4	2.7	1.2	2.5	1.0	4.2	1.3	3.8	1.3	3.4	1.2	3.1	1.0		

The maximum overhangs (O/H) have been determined for a maximum birdsmouth D/3 - see diagram on page 46

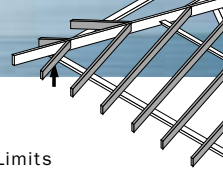

# RAFTERS

Design Wind Speed 33 m/s

Design Deflection Limits  
 D.L. L.L.  
 SPAN/300 SPAN/300  
 OR 20 mm OR 12.5 mm

HYSPAN SECTION D X B (mm)	ROOF MASS kg/m <sup>2</sup>	SINGLE SPAN								CONTINUOUS SPAN									
		MAXIMUM RAFTER SPACING (mm)																	
		450		600		900		1200		450		600		900		1200			
		MAXIMUM RAFTER SPAN AND OVERHANG 'O/H' (m)																	
SPAN		O/H		SPAN		O/H		SPAN		O/H		SPAN		O/H		SPAN		O/H	
150 x 45	10	5.3	1.3	5.1	1.2	4.8	1.1	4.6	0.9	6.4	1.2	6.2	1.1	5.8	1.0	5.5	0.9		
	20	5.3	1.3	5.1	1.2	4.6	1.1	4.2	0.9	6.4	1.2	6.2	1.1	5.7	1.0	5.2	0.9		
	30	4.9	1.4	4.6	1.3	4.1	1.1	3.8	0.9	6.1	1.2	5.7	1.2	5.1	1.1	4.6	0.9		
	40	4.6	1.4	4.2	1.4	3.8	1.1	3.4	0.9	5.7	1.3	5.2	1.2	4.6	1.1	4.3	0.9		
	60	4.1	1.5	3.8	1.4	3.3	1.2	3.0	1.0	5.1	1.4	4.6	1.3	4.1	1.2	3.8	1.0		
	75	3.8	1.6	3.5	1.5	3.1	1.3	2.8	1.1	4.7	1.4	4.3	1.3	3.8	1.3	3.5	1.1		
	90	3.6	1.6	3.3	1.5	2.9	1.4	2.7	1.1	4.5	1.5	4.1	1.4	3.6	1.3	3.3	1.1		
170 x 36	10	5.5	1.4	5.3	1.3	5.0	1.0	4.8	0.9	6.7	1.2	6.5	1.1	6.1	1.0	5.8	0.9		
	20	5.5	1.4	5.3	1.3	4.9	1.1	4.5	0.9	6.7	1.2	6.5	1.1	6.0	1.1	5.5	0.9		
	30	5.2	1.4	4.9	1.3	4.3	1.1	4.0	0.9	6.4	1.3	6.0	1.2	5.3	1.1	4.9	0.9		
	40	4.9	1.5	4.5	1.4	4.0	1.1	3.6	0.9	6.0	1.3	5.5	1.3	4.9	1.1	4.5	0.9		
	60	4.3	1.6	4.0	1.5	3.5	1.2	3.2	1.0	5.3	1.4	4.9	1.3	4.3	1.2	4.0	1.0		
	75	4.0	1.7	3.7	1.5	3.3	1.3	3.0	1.0	5.0	1.5	4.6	1.4	4.0	1.3	3.7	1.0		
	90	3.8	1.7	3.5	1.6	3.1	1.3	2.8	1.1	4.7	1.5	4.3	1.4	3.8	1.3	3.5	1.1		
170 x 45	10	5.9	1.5	5.7	1.4	5.4	1.2	5.1	1.0	7.2	1.4	7.0	1.2	6.6	1.1	6.2	1.0		
	20	5.9	1.5	5.7	1.4	5.2	1.2	4.8	1.0	7.1	1.4	6.8	1.3	6.3	1.2	5.9	1.0		
	30	5.5	1.6	5.2	1.5	4.6	1.2	4.2	1.0	6.6	1.4	6.3	1.3	5.7	1.2	5.2	1.0		
	40	5.2	1.6	4.8	1.5	4.2	1.3	3.9	1.1	6.3	1.5	5.9	1.4	5.2	1.3	4.8	1.1		
	60	4.6	1.7	4.2	1.6	3.8	1.4	3.4	1.1	5.7	1.5	5.2	1.5	4.6	1.4	4.2	1.1		
	75	4.3	1.8	4.0	1.7	3.5	1.4	3.2	1.2	5.3	1.6	4.9	1.5	4.3	1.4	4.0	1.2		
	90	4.1	1.8	3.8	1.7	3.3	1.5	3.0	1.2	5.1	1.6	4.6	1.5	4.1	1.4	3.7	1.2		
200 x 36	10	6.4	1.6	6.2	1.5	5.8	1.2	5.5	1.0	7.9	1.4	7.6	1.3	7.1	1.2	6.6	1.0		
	20	6.4	1.6	6.2	1.5	5.7	1.2	5.2	1.0	7.6	1.5	7.3	1.4	6.7	1.2	6.3	1.0		
	30	6.1	1.7	5.7	1.6	5.1	1.2	4.6	1.0	7.1	1.5	6.7	1.4	6.2	1.2	5.7	1.0		
	40	5.7	1.7	5.2	1.6	4.6	1.3	4.3	1.1	6.7	1.6	6.3	1.5	5.7	1.3	5.3	1.1		
	60	5.1	1.9	4.6	1.7	4.1	1.4	3.8	1.1	6.2	1.7	5.7	1.6	5.1	1.4	4.6	1.1		
	75	4.7	1.9	4.3	1.8	3.8	1.4	3.5	1.2	5.9	1.7	5.4	1.6	4.7	1.4	4.3	1.2		
	90	4.5	2.0	4.1	1.8	3.6	1.5	3.3	1.2	5.5	1.8	5.1	1.7	4.5	1.5	4.1	1.2		
200 x 45	10	6.9	1.8	6.7	1.6	6.3	1.3	5.9	1.1	-	-	8.1	1.5	7.5	1.3	7.0	1.1		
	20	6.8	1.8	6.4	1.7	6.0	1.4	5.6	1.1	7.9	1.6	7.6	1.5	7.0	1.4	6.6	1.1		
	30	6.3	1.9	6.0	1.7	5.4	1.4	5.0	1.2	7.4	1.7	7.0	1.6	6.5	1.4	6.1	1.2		
	40	6.0	1.9	5.6	1.8	5.0	1.5	4.6	1.2	7.0	1.8	6.6	1.6	6.1	1.5	5.6	1.2		
	60	5.4	2.0	5.0	1.9	4.4	1.6	4.0	1.3	6.5	1.8	6.1	1.7	5.4	1.6	5.0	1.3		
	75	5.1	2.1	4.6	1.9	4.1	1.6	3.8	1.3	6.2	1.9	5.7	1.8	5.1	1.6	4.6	1.3		
	90	4.8	2.1	4.4	2.0	3.9	1.7	3.5	1.4	5.9	1.9	5.4	1.8	4.8	1.7	4.4	1.4		

The maximum overhangs (O/H) have been determined for a maximum birdsmouth D/3 - see diagram on page 46

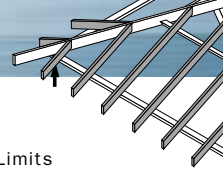

# RAFTERS

Design Wind Speed 33 m/s

Design Deflection Limits  
 D.L. L.L.  
 SPAN/300 SPAN/300  
 OR 20 mm OR 12.5 mm

HYSPAN SECTION D X B (mm)	ROOF MASS kg/m <sup>2</sup>	SINGLE SPAN								CONTINUOUS SPAN									
		MAXIMUM RAFTER SPACING (mm)																	
		450		600		900		1200		450		600		900		1200			
		MAXIMUM RAFTER SPAN AND OVERHANG 'O/H' (m)																	
SPAN		O/H		SPAN		O/H		SPAN		O/H		SPAN		O/H		SPAN		O/H	
240 x 45	10	8.2	2.1	7.9	1.9	7.4	1.6	6.8	1.3	-	-	-	-	-	-	8.0	1.3		
	20	7.6	2.2	7.3	2.0	6.8	1.6	6.4	1.3	-	-	-	-	8.0	1.6	7.5	1.3		
	30	7.1	2.3	6.8	2.1	6.3	1.6	5.9	1.4	-	-	8.0	1.9	7.4	1.6	6.9	1.4		
	40	6.8	2.4	6.4	2.2	5.9	1.7	5.4	1.4	8.0	2.2	7.5	2.0	6.9	1.7	6.5	1.4		
	60	6.3	2.4	5.9	2.2	5.2	1.8	4.8	1.5	7.4	2.2	6.9	2.1	6.4	1.8	5.9	1.5		
	75	6.0	2.5	5.5	2.3	4.9	1.9	4.5	1.6	7.0	2.3	6.6	2.1	6.0	1.9	5.5	1.6		
	90	5.7	2.6	5.2	2.4	4.6	2.0	4.2	1.6	6.8	2.4	6.4	2.2	5.7	2.0	5.2	1.6		
240 x 63	10	8.5	2.5	8.3	2.3	8.0	1.9	7.4	1.6	-	-	-	-	-	-	-	-		
	20	8.0	2.6	7.7	2.4	7.2	1.9	6.9	1.6	-	-	-	-	-	-	8.0	1.6		
	30	7.5	2.7	7.2	2.4	6.7	2.0	6.3	1.6	-	-	-	-	7.9	2.0	7.4	1.6		
	40	7.2	2.7	6.9	2.5	6.3	2.1	6.0	1.7	-	-	8.0	2.3	7.4	2.1	7.0	1.7		
	60	6.7	2.8	6.3	2.6	5.8	2.2	5.3	1.8	7.9	2.6	7.4	2.4	6.8	2.2	6.4	1.8		
	75	6.4	2.9	6.1	2.6	5.4	2.3	5.0	1.9	7.5	2.7	7.1	2.5	6.5	2.3	6.1	1.9		
	90	6.2	2.9	5.8	2.7	5.1	2.5	4.7	2.0	7.3	2.7	6.8	2.5	6.3	2.3	5.8	2.0		
300 x 45	10	9.5	2.7	9.2	2.5	8.7	1.9	8.1	1.5	-	-	-	-	-	-	-	-		
	20	8.8	2.9	8.4	2.5	7.9	1.9	7.5	1.6	-	-	-	-	-	-	-	-		
	30	8.3	3.0	7.9	2.6	7.3	2.0	6.9	1.6	-	-	-	-	-	-	8.1	1.6		
	40	7.9	3.0	7.5	2.7	6.9	2.0	6.5	1.7	-	-	-	-	8.1	2.0	7.7	1.7		
	60	7.3	3.1	6.9	2.9	6.4	2.2	6.0	1.8	-	-	8.1	2.7	7.5	2.2	7.0	1.8		
	75	7.0	3.2	6.6	2.9	6.1	2.3	5.6	1.9	-	-	7.8	2.7	7.1	2.3	6.7	1.9		
	90	6.8	3.2	6.4	3.0	5.8	2.4	5.3	2.0	7.9	3.0	7.5	2.8	6.8	2.4	6.4	2.0		
300 x 63	10	9.7	3.3	9.5	3.0	9.1	2.3	8.8	1.9	-	-	-	-	-	-	-	-		
	20	9.1	3.4	8.8	3.1	8.3	2.3	8.0	1.9	-	-	-	-	-	-	-	-		
	30	8.7	3.4	8.3	3.1	7.8	2.4	7.4	2.0	-	-	-	-	-	-	-	-		
	40	8.3	3.5	8.0	3.2	7.4	2.5	7.0	2.0	-	-	-	-	-	-	8.2	2.0		
	60	7.8	3.6	7.4	3.3	6.8	2.7	6.4	2.2	-	-	-	-	8.0	2.7	7.5	2.2		
	75	7.5	3.6	7.1	3.4	6.5	2.8	6.1	2.3	-	-	-	-	7.6	2.8	7.2	2.3		
	90	7.2	3.4	6.8	3.2	6.3	3.0	5.8	2.4	-	-	8.0	3.2	7.4	2.9	6.9	2.4		
400 x 63	10	11.4	4.6	11.2	3.9	10.8	2.9	10.5	2.4	-	-	-	-	-	-	-	-		
	20	10.8	4.7	10.5	4.0	10.0	3.0	9.6	2.5	-	-	-	-	-	-	-	-		
	30	10.4	4.8	10.0	4.1	9.5	3.1	9.0	2.5	-	-	-	-	-	-	-	-		
	40	10.0	4.8	9.6	4.3	9.0	3.2	8.6	2.6	-	-	-	-	-	-	-	-		
	60	9.5	4.5	9.0	4.3	8.4	3.4	7.9	2.8	-	-	-	-	-	-	-	-		
	75	9.1	4.3	8.7	4.1	8.0	3.6	7.5	2.9	-	-	-	-	-	-	-	-		
	90	8.8	4.2	8.4	4.0	7.7	3.6	7.2	3.1	-	-	-	-	-	-	-	-		

The maximum overhangs (O/H) have been determined for a maximum birdsmouth D/3 - see diagram on page 46

Rafters

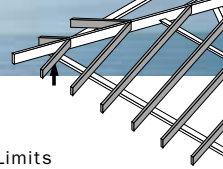

# RAFTERS

Design Wind Speed 41 m/s

Design Deflection Limits  
 D.L. L.L.  
 SPAN/300 SPAN/300  
 OR 20 mm OR 12.5 mm

HYSPAN SECTION D X B (mm)	ROOF MASS kg/m <sup>2</sup>	SINGLE SPAN								CONTINUOUS SPAN									
		MAXIMUM RAFTER SPACING (mm)																	
		450		600		900		1200		450		600		900		1200			
		MAXIMUM RAFTER SPAN AND OVERHANG 'O/H' (m)																	
SPAN		O/H		SPAN		O/H		SPAN		O/H		SPAN		O/H		SPAN		O/H	
95 x 36	10	2.9	0.8	2.8	0.6	2.6	0.5	2.4	0.4	3.9	0.7	3.6	0.6	2.9	0.5	2.5	0.4		
	20	2.9	0.8	2.8	0.7	2.6	0.5	2.4	0.4	3.9	0.7	3.7	0.7	3.0	0.5	2.6	0.4		
	30	2.9	0.8	2.8	0.7	2.5	0.5	2.3	0.4	3.7	0.7	3.4	0.7	3.0	0.5	2.7	0.4		
	40	2.8	0.8	2.6	0.7	2.3	0.5	2.1	0.4	3.4	0.8	3.2	0.7	2.8	0.5	2.5	0.4		
	60	2.5	0.9	2.3	0.7	2.0	0.5	1.8	0.4	3.0	0.8	2.8	0.7	2.4	0.5	2.2	0.4		
	75	2.3	0.9	2.1	0.7	1.8	0.6	1.7	0.5	2.8	0.9	2.6	0.7	2.3	0.6	2.1	0.5		
	90	2.2	0.9	2.0	0.8	1.7	0.6	1.6	0.5	2.7	0.9	2.4	0.8	2.1	0.6	2.0	0.5		
95 x 45	10	3.2	0.9	3.1	0.7	2.9	0.6	2.7	0.5	4.2	0.8	4.0	0.7	3.4	0.6	2.9	0.5		
	20	3.2	0.9	3.1	0.7	2.9	0.6	2.7	0.5	4.2	0.8	4.0	0.7	3.5	0.6	3.0	0.5		
	30	3.2	0.9	3.0	0.8	2.6	0.6	2.4	0.5	4.0	0.8	3.7	0.8	3.3	0.6	3.0	0.5		
	40	3.0	0.9	2.7	0.8	2.4	0.6	2.2	0.5	3.7	0.8	3.4	0.8	3.0	0.6	2.7	0.5		
	60	2.6	1.0	2.4	0.8	2.1	0.6	1.9	0.5	3.3	0.9	3.0	0.8	2.6	0.6	2.4	0.5		
	75	2.5	1.0	2.3	0.8	2.0	0.6	1.8	0.5	3.0	0.9	2.8	0.8	2.4	0.6	2.2	0.5		
	90	2.3	1.0	2.1	0.9	1.9	0.6	1.7	0.5	2.9	1.0	2.6	0.9	2.3	0.6	2.1	0.5		
130 x 36	10	4.3	1.0	4.1	0.8	3.7	0.6	3.2	0.5	5.2	1.0	4.6	0.8	3.8	0.6	3.2	0.5		
	20	4.3	1.0	4.1	0.8	3.8	0.6	3.3	0.5	5.2	1.0	4.8	0.8	3.9	0.6	3.4	0.5		
	30	4.1	1.0	3.8	0.9	3.3	0.7	3.1	0.5	5.0	1.0	4.6	0.9	4.0	0.7	3.5	0.5		
	40	3.8	1.1	3.5	0.9	3.1	0.7	2.8	0.6	4.6	1.0	4.3	0.9	3.8	0.7	3.5	0.6		
	60	3.3	1.1	3.1	0.9	2.7	0.7	2.5	0.6	4.1	1.1	3.8	0.9	3.3	0.7	3.0	0.6		
	75	3.1	1.1	2.9	0.9	2.5	0.7	2.3	0.6	3.9	1.1	3.5	0.9	3.1	0.7	2.8	0.6		
	90	2.9	1.2	2.7	1.0	2.4	0.7	2.2	0.6	3.6	1.2	3.3	1.0	2.9	0.7	2.7	0.6		
130 x 45	10	4.6	1.1	4.4	0.9	4.2	0.7	3.8	0.6	5.6	1.0	5.4	0.9	4.5	0.7	3.9	0.6		
	20	4.6	1.2	4.4	1.0	4.0	0.7	3.7	0.6	5.6	1.0	5.4	1.0	4.7	0.7	4.1	0.6		
	30	4.3	1.2	4.0	1.0	3.6	0.7	3.3	0.6	5.4	1.1	5.0	1.0	4.4	0.7	4.0	0.6		
	40	4.0	1.2	3.7	1.0	3.3	0.8	3.0	0.6	5.0	1.1	4.6	1.0	4.0	0.8	3.7	0.6		
	60	3.6	1.3	3.3	1.0	2.9	0.8	2.6	0.7	4.4	1.2	4.0	1.0	3.6	0.8	3.3	0.7		
	75	3.3	1.3	3.1	1.1	2.7	0.8	2.5	0.7	4.1	1.2	3.8	1.1	3.3	0.8	3.0	0.7		
	90	3.2	1.3	2.9	1.1	2.5	0.8	2.3	0.7	3.9	1.3	3.6	1.1	3.1	0.8	2.9	0.7		
150 x 36	10	4.9	1.1	4.7	0.9	4.1	0.7	3.5	0.6	6.0	1.1	5.2	0.9	4.2	0.7	3.6	0.6		
	20	4.9	1.1	4.7	0.9	4.2	0.7	3.7	0.6	6.0	1.1	5.4	0.9	4.4	0.7	3.8	0.6		
	30	4.7	1.2	4.3	1.0	3.8	0.7	3.5	0.6	5.8	1.1	5.3	1.0	4.5	0.7	3.9	0.6		
	40	4.3	1.2	4.0	1.0	3.5	0.8	3.2	0.6	5.3	1.2	4.9	1.0	4.3	0.8	4.0	0.6		
	60	3.8	1.2	3.5	1.0	3.1	0.8	2.8	0.6	4.7	1.2	4.3	1.0	3.8	0.8	3.5	0.6		
	75	3.6	1.3	3.3	1.1	2.9	0.8	2.6	0.7	4.4	1.3	4.1	1.1	3.6	0.8	3.3	0.7		
	90	3.4	1.3	3.1	1.1	2.7	0.8	2.5	0.7	4.2	1.3	3.8	1.1	3.4	0.8	3.1	0.7		

The maximum overhangs (O/H) have been determined for a maximum birdsmouth D/3 - see diagram on page 46

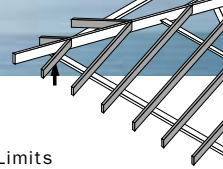

# RAFTERS

Design Wind Speed 41 m/s

Design Deflection Limits  
 D.L. L.L.  
 SPAN/300 SPAN/300  
 OR 20 mm OR 12.5 mm

HYSPAN SECTION D X B (mm)	ROOF MASS kg/m <sup>2</sup>	SINGLE SPAN								CONTINUOUS SPAN									
		MAXIMUM RAFTER SPACING (mm)																	
		450		600		900		1200		450		600		900		1200			
		MAXIMUM RAFTER SPAN AND OVERHANG 'O/H' (m)																	
SPAN		O/H		SPAN		O/H		SPAN		O/H		SPAN		O/H		SPAN		O/H	
150 x 45	10	5.3	1.3	5.1	1.1	4.8	0.8	4.3	0.7	6.4	1.2	6.2	1.1	5.1	0.8	4.4	0.7		
	20	5.3	1.3	5.1	1.1	4.6	0.8	4.2	0.7	6.4	1.2	6.2	1.1	5.3	0.8	4.6	0.7		
	30	4.9	1.3	4.6	1.1	4.1	0.8	3.8	0.7	6.1	1.2	5.7	1.1	5.1	0.8	4.6	0.7		
	40	4.6	1.4	4.2	1.1	3.8	0.9	3.4	0.7	5.7	1.3	5.2	1.1	4.6	0.9	4.3	0.7		
	60	4.1	1.4	3.8	1.2	3.3	0.9	3.0	0.7	5.1	1.4	4.6	1.2	4.1	0.9	3.8	0.7		
	75	3.8	1.5	3.5	1.2	3.1	0.9	2.8	0.8	4.7	1.4	4.3	1.2	3.8	0.9	3.5	0.8		
	90	3.6	1.5	3.3	1.2	2.9	0.9	2.7	0.8	4.5	1.5	4.1	1.2	3.6	0.9	3.3	0.8		
170 x 36	10	5.5	1.2	5.3	1.0	4.5	0.8	3.9	0.7	6.7	1.2	5.7	1.0	4.6	0.8	4.0	0.7		
	20	5.5	1.3	5.3	1.1	4.7	0.8	4.0	0.7	6.7	1.2	5.9	1.1	4.8	0.8	4.1	0.7		
	30	5.2	1.3	4.9	1.1	4.3	0.8	4.0	0.7	6.4	1.3	6.0	1.1	5.0	0.8	4.3	0.7		
	40	4.9	1.3	4.5	1.1	4.0	0.8	3.6	0.7	6.0	1.3	5.5	1.1	4.9	0.8	4.5	0.7		
	60	4.3	1.4	4.0	1.1	3.5	0.9	3.2	0.7	5.3	1.4	4.9	1.1	4.3	0.9	4.0	0.7		
	75	4.0	1.4	3.7	1.2	3.3	0.9	3.0	0.7	5.0	1.4	4.6	1.2	4.0	0.9	3.7	0.7		
	90	3.8	1.5	3.5	1.2	3.1	0.9	2.8	0.8	4.7	1.5	4.3	1.2	3.8	0.9	3.5	0.8		
170 x 45	10	5.9	1.4	5.7	1.2	5.4	0.9	4.8	0.7	7.2	1.4	7.0	1.2	5.7	0.9	4.9	0.7		
	20	5.9	1.4	5.7	1.2	5.2	0.9	4.8	0.8	7.1	1.4	6.8	1.2	5.9	0.9	5.1	0.8		
	30	5.5	1.5	5.2	1.2	4.6	0.9	4.2	0.8	6.6	1.4	6.3	1.2	5.7	0.9	5.2	0.8		
	40	5.2	1.5	4.8	1.2	4.2	0.9	3.9	0.8	6.3	1.5	5.9	1.2	5.2	0.9	4.8	0.8		
	60	4.6	1.6	4.2	1.3	3.8	1.0	3.4	0.8	5.7	1.5	5.2	1.3	4.6	1.0	4.2	0.8		
	75	4.3	1.6	4.0	1.3	3.5	1.0	3.2	0.8	5.3	1.6	4.9	1.3	4.3	1.0	4.0	0.8		
	90	4.1	1.7	3.8	1.4	3.3	1.0	3.0	0.9	5.1	1.6	4.6	1.4	4.1	1.0	3.7	0.9		
200 x 36	10	6.4	1.4	6.2	1.2	5.1	0.9	4.4	0.7	7.5	1.4	6.5	1.2	5.2	0.9	4.5	0.7		
	20	6.4	1.5	6.2	1.2	5.3	0.9	4.5	0.8	7.6	1.5	6.7	1.2	5.4	0.9	4.7	0.8		
	30	6.1	1.5	5.7	1.2	5.1	0.9	4.6	0.8	7.1	1.5	6.7	1.2	5.6	0.9	4.9	0.8		
	40	5.7	1.5	5.2	1.2	4.6	0.9	4.3	0.8	6.7	1.5	6.3	1.2	5.7	0.9	5.1	0.8		
	60	5.1	1.6	4.6	1.3	4.1	1.0	3.8	0.8	6.2	1.6	5.7	1.3	5.1	1.0	4.6	0.8		
	75	4.7	1.6	4.3	1.3	3.8	1.0	3.5	0.8	5.9	1.6	5.4	1.3	4.7	1.0	4.3	0.8		
	90	4.5	1.7	4.1	1.4	3.6	1.0	3.3	0.9	5.5	1.7	5.1	1.4	4.5	1.0	4.1	0.9		
200 x 45	10	6.9	1.6	6.7	1.3	6.3	1.0	5.5	0.8	-	-	8.1	1.3	6.6	1.0	5.6	0.8		
	20	6.8	1.7	6.4	1.4	6.0	1.0	5.6	0.9	7.9	1.6	7.6	1.4	6.8	1.0	5.9	0.9		
	30	6.3	1.7	6.0	1.4	5.4	1.1	5.0	0.9	7.4	1.7	7.0	1.4	6.5	1.1	6.1	0.9		
	40	6.0	1.7	5.6	1.4	5.0	1.1	4.6	0.9	7.0	1.7	6.6	1.4	6.1	1.1	5.6	0.9		
	60	5.4	1.8	5.0	1.5	4.4	1.1	4.0	0.9	6.5	1.8	6.1	1.5	5.4	1.1	5.0	0.9		
	75	5.1	1.9	4.6	1.5	4.1	1.2	3.8	0.9	6.2	1.9	5.7	1.5	5.1	1.2	4.6	0.9		
	90	4.8	1.9	4.4	1.6	3.9	1.2	3.5	1.0	5.9	1.9	5.4	1.6	4.8	1.2	4.4	1.0		

The maximum overhangs (O/H) have been determined for a maximum birdsmouth D/3 - see diagram on page 46

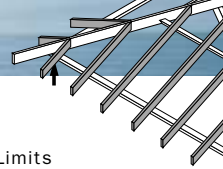

# RAFTERS

Design Wind Speed 41 m/s

Design Deflection Limits  
 D.L. L.L.  
 SPAN/300 SPAN/300  
 OR 20 mm OR 12.5 mm

HYSPAN SECTION D X B (mm)	ROOF MASS kg/m <sup>2</sup>	SINGLE SPAN								CONTINUOUS SPAN									
		MAXIMUM RAFTER SPACING (mm)																	
		450		600		900		1200		450		600		900		1200			
		MAXIMUM RAFTER SPAN AND OVERHANG 'O/H' (m)																	
SPAN		O/H		SPAN		O/H		SPAN		O/H		SPAN		O/H		SPAN		O/H	
240 x 45	10	8.2	1.9	7.9	1.6	7.4	1.2	6.4	1.0	-	-	-	-	7.6	1.2	6.5	1.0		
	20	7.6	1.9	7.3	1.6	6.8	1.2	6.4	1.0	-	-	-	-	7.9	1.2	6.8	1.0		
	30	7.1	2.0	6.8	1.6	6.3	1.2	5.9	1.0	-	-	8.0	1.6	7.4	1.2	6.9	1.0		
	40	6.8	2.0	6.4	1.6	5.9	1.3	5.4	1.0	8.0	2.0	7.5	1.6	6.9	1.3	6.5	1.0		
	60	6.3	2.1	5.9	1.7	5.2	1.3	4.8	1.1	7.4	2.1	6.9	1.7	6.4	1.3	5.9	1.1		
	75	6.0	2.2	5.5	1.8	4.9	1.3	4.5	1.1	7.0	2.2	6.6	1.8	6.0	1.3	5.5	1.1		
	90	5.7	2.2	5.2	1.8	4.6	1.4	4.2	1.1	6.8	2.2	6.4	1.8	5.7	1.4	5.2	1.1		
240 x 63	10	8.5	2.3	8.3	1.9	8.0	1.4	7.4	1.2	-	-	-	-	-	-	-	-		
	20	8.0	2.3	7.7	1.9	7.2	1.5	6.9	1.2	-	-	-	-	-	-	8.0	1.2		
	30	7.5	2.4	7.2	2.0	6.7	1.5	6.3	1.2	-	-	-	-	7.9	1.5	7.4	1.2		
	40	7.2	2.4	6.9	2.0	6.3	1.5	6.0	1.3	-	-	8.0	2.0	7.4	1.5	7.0	1.3		
	60	6.7	2.5	6.3	2.1	5.8	1.6	5.3	1.3	7.9	2.5	7.4	2.1	6.8	1.6	6.4	1.3		
	75	6.4	2.6	6.1	2.2	5.4	1.6	5.0	1.3	7.5	2.6	7.1	2.2	6.5	1.6	6.1	1.3		
	90	6.2	2.7	5.8	2.2	5.1	1.7	4.7	1.4	7.3	2.7	6.8	2.2	6.3	1.7	5.8	1.4		
300 x 45	10	9.5	2.3	9.2	1.9	8.5	1.4	7.3	1.2	-	-	-	-	-	-	-	-		
	20	8.8	2.3	8.4	1.9	7.9	1.5	7.5	1.2	-	-	-	-	-	-	8.0	1.2		
	30	8.3	2.4	7.9	2.0	7.3	1.5	6.9	1.2	-	-	-	-	-	-	8.1	1.2		
	40	7.9	2.4	7.5	2.0	6.9	1.5	6.5	1.2	-	-	-	-	8.1	1.5	7.7	1.2		
	60	7.3	2.5	6.9	2.1	6.4	1.6	6.0	1.3	-	-	8.1	2.1	7.5	1.6	7.0	1.3		
	75	7.0	2.6	6.6	2.1	6.1	1.6	5.6	1.3	-	-	7.8	2.1	7.1	1.6	6.7	1.3		
	90	6.8	2.7	6.4	2.2	5.8	1.7	5.3	1.4	7.9	2.7	7.5	2.2	6.8	1.7	6.4	1.4		
300 x 63	10	9.7	2.8	9.5	2.3	9.1	1.7	8.8	1.4	-	-	-	-	-	-	-	-		
	20	9.1	2.8	8.8	2.3	8.3	1.8	8.0	1.5	-	-	-	-	-	-	-	-		
	30	8.7	2.9	8.3	2.4	7.8	1.8	7.4	1.5	-	-	-	-	-	-	-	-		
	40	8.3	3.0	8.0	2.4	7.4	1.8	7.0	1.5	-	-	-	-	-	-	8.2	1.5		
	60	7.8	3.1	7.4	2.5	6.8	1.9	6.4	1.6	-	-	-	-	8.0	1.9	7.5	1.6		
	75	7.5	3.2	7.1	2.6	6.5	2.0	6.1	1.6	-	-	-	-	7.6	2.0	7.2	1.6		
	90	7.2	3.3	6.8	2.7	6.3	2.0	5.8	1.7	-	-	8.0	2.7	7.4	2.0	6.9	1.7		
400 x 63	10	11.4	3.6	11.2	2.9	10.8	2.2	10.5	1.8	-	-	-	-	-	-	-	-		
	20	10.8	3.6	10.5	3.0	10.0	2.2	9.6	1.8	-	-	-	-	-	-	-	-		
	30	10.4	3.7	10.0	3.0	9.5	2.3	9.0	1.9	-	-	-	-	-	-	-	-		
	40	10.0	3.8	9.6	3.1	9.0	2.3	8.6	1.9	-	-	-	-	-	-	-	-		
	60	9.5	4.0	9.0	3.2	8.4	2.4	7.9	2.0	-	-	-	-	-	-	-	-		
	75	9.1	4.1	8.7	3.3	8.0	2.5	7.5	2.0	-	-	-	-	-	-	-	-		
	90	8.8	4.2	8.4	3.5	7.7	2.6	7.2	2.1	-	-	-	-	-	-	-	-		

The maximum overhangs (O/H) have been determined for a maximum birdsmouth D/3 - see diagram on page 46

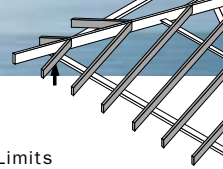

# RAFTERS

Widely Spaced - Design Wind Speed 33 m/s

Design Deflection Limits  
 D.L. L.L.  
 SPAN/300 SPAN/300  
 OR 20 mm OR 12.5 mm

HYSPAN SECTION D X B (mm)	ROOF MASS kg/m <sup>2</sup>	MAXIMUM RAFTER SPACING (m)														
		1.8			2.1			2.4			2.7			3.0		
		MAXIMUM SINGLE SPAN AND OVERHANG 'O/H' (mm)														
		SPAN	O/H <sup>1</sup>	O/H <sup>2</sup>	SPAN	O/H <sup>1</sup>	O/H <sup>2</sup>	SPAN	O/H <sup>1</sup>	O/H <sup>2</sup>	SPAN	O/H <sup>1</sup>	O/H <sup>2</sup>	SPAN	O/H <sup>1</sup>	O/H <sup>2</sup>
150 x 45	10	4.2	1.2	0.7	4.0	1.2	0.6	3.9	1.2	0.6	3.8	1.2	0.5	3.6	1.2	0.5
	20	3.8	1.2	0.7	3.6	1.2	0.6	3.4	1.2	0.6	3.3	1.2	0.5	3.2	1.2	0.5
	30	3.3	1.3	0.7	3.2	1.3	0.6	3.0	1.3	0.6	2.9	1.3	0.5	2.8	1.3	0.5
	40	3.0	1.4	0.7	2.9	1.3	0.7	2.8	1.3	0.6	2.7	1.3	0.6	2.6	1.3	0.5
150 x 63	10	4.6	1.3	0.8	4.4	1.3	0.7	4.3	1.3	0.7	4.1	1.3	0.6	4.0	1.3	0.6
	20	4.2	1.4	0.8	4.0	1.4	0.8	3.8	1.4	0.7	3.7	1.4	0.7	3.6	1.4	0.6
	30	3.7	1.5	0.9	3.5	1.5	0.8	3.4	1.4	0.7	3.3	1.4	0.7	3.1	1.4	0.6
	40	3.4	1.5	0.9	3.2	1.5	0.8	3.1	1.5	0.7	3.0	1.5	0.7	2.9	1.5	0.6
150 x 75	10	4.9	1.4	0.9	4.7	1.4	0.8	4.5	1.4	0.8	4.4	1.4	0.7	4.2	1.4	0.7
	20	4.4	1.5	0.9	4.2	1.5	0.8	4.0	1.5	0.8	3.9	1.5	0.7	3.8	1.4	0.7
	30	3.9	1.5	0.9	3.7	1.5	0.9	3.6	1.5	0.8	3.4	1.5	0.7	3.3	1.5	0.7
	40	3.6	1.6	1.0	3.4	1.6	0.9	3.3	1.6	0.8	3.1	1.6	0.8	3.0	1.6	0.7
170 x 36	10	4.4	1.3	0.7	4.2	1.3	0.6	4.1	1.2	0.5	3.9	1.2	0.5	3.8	1.2	0.5
	20	4.0	1.3	0.7	3.8	1.3	0.6	3.6	1.3	0.6	3.5	1.3	0.5	3.4	1.3	0.5
	30	3.5	1.4	0.7	3.3	1.4	0.6	3.2	1.4	0.6	3.1	1.4	0.5	3.0	1.3	0.5
	40	3.2	1.4	0.7	3.0	1.4	0.6	2.9	1.4	0.6	2.8	1.4	0.5	2.7	1.4	0.5
170 x 45	10	4.7	1.4	0.7	4.5	1.3	0.7	4.3	1.3	0.6	4.2	1.3	0.6	4.1	1.3	0.5
	20	4.2	1.4	0.8	4.1	1.4	0.7	3.9	1.4	0.6	3.8	1.4	0.6	3.6	1.4	0.6
	30	3.8	1.5	0.8	3.6	1.5	0.7	3.4	1.5	0.7	3.3	1.5	0.6	3.2	1.4	0.6
	40	3.4	1.5	0.8	3.3	1.5	0.7	3.1	1.5	0.7	3.0	1.5	0.6	2.9	1.5	0.6
200 x 36	10	5.1	1.5	0.7	4.9	1.5	0.7	4.7	1.5	0.6	4.5	1.5	0.6	4.2	1.5	0.5
	20	4.6	1.5	0.8	4.4	1.5	0.7	4.3	1.5	0.6	4.1	1.5	0.6	4.0	1.5	0.6
	30	4.1	1.6	0.8	3.9	1.6	0.7	3.8	1.6	0.7	3.6	1.6	0.6	3.5	1.6	0.6
	40	3.8	1.6	0.8	3.6	1.6	0.7	3.4	1.6	0.7	3.3	1.6	0.6	3.2	1.6	0.6
200 x 45	10	5.4	1.6	0.8	5.2	1.6	0.8	5.0	1.6	0.7	4.8	1.6	0.7	4.7	1.6	0.6
	20	5.0	1.6	0.9	4.7	1.6	0.8	4.6	1.6	0.7	4.4	1.6	0.7	4.3	1.6	0.6
	30	4.4	1.7	0.9	4.2	1.7	0.8	4.0	1.7	0.7	3.9	1.7	0.7	3.8	1.7	0.7
	40	4.0	1.8	0.9	3.8	1.8	0.8	3.7	1.8	0.8	3.5	1.8	0.7	3.4	1.7	0.7
240 x 45	10	6.2	1.9	1.0	5.9	1.9	0.9	5.8	1.9	0.8	5.6	1.9	0.8	5.4	1.9	0.7
	20	5.9	2.0	1.0	5.6	2.0	0.9	5.4	2.0	0.8	5.2	1.9	0.8	5.1	1.9	0.7
	30	5.2	2.1	1.0	5.0	2.0	0.9	4.8	2.0	0.9	4.6	2.0	0.8	4.5	2.0	0.8
	40	4.8	2.1	1.1	4.6	2.1	1.0	4.4	2.1	0.9	4.2	2.1	0.8	4.1	2.1	0.8
240 x 63	10	6.7	2.2	1.2	6.5	2.2	1.1	6.3	2.1	1.0	6.1	2.1	0.9	5.9	2.1	0.9
	20	6.3	2.2	1.2	6.2	2.2	1.1	6.0	2.2	1.0	5.8	2.2	1.0	5.6	2.2	0.9
	30	5.8	2.3	1.3	5.5	2.3	1.1	5.3	2.3	1.0	5.1	2.3	1.0	5.0	2.3	0.9
	40	5.3	2.4	1.3	5.1	2.4	1.2	4.9	2.3	1.1	4.7	2.3	1.0	4.6	2.3	0.9

Overhang O/H<sup>1</sup> applies only where the rafter is not birdsmouthed.

Overhang O/H<sup>2</sup> applies for birdsmouths not exceeding D/3 - see page 46.



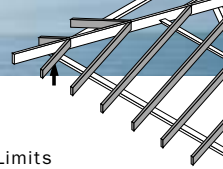

# RAFTERS

Widely Spaced - Design Wind Speed 33 m/s

Design Deflection Limits  
 D.L. L.L.  
 SPAN/300 SPAN/300  
 OR 20 mm OR 12.5 mm

HYSPAN SECTION D X B (mm)	ROOF MASS kg/m <sup>2</sup>	MAXIMUM RAFTER SPACING (m)														
		1.8			2.1			2.4			2.7			3.0		
		MAXIMUM SINGLE SPAN AND OVERHANG 'O/H' (mm)														
		SPAN	O/H <sup>1</sup>	O/H <sup>2</sup>	SPAN	O/H <sup>1</sup>	O/H <sup>2</sup>	SPAN	O/H <sup>1</sup>	O/H <sup>2</sup>	SPAN	O/H <sup>1</sup>	O/H <sup>2</sup>	SPAN	O/H <sup>1</sup>	O/H <sup>2</sup>
300 x 45	10	7.3	2.5	1.2	7.0	2.4	1.1	6.8	2.4	1.0	6.6	2.4	0.9	6.4	2.4	0.9
	20	6.9	2.5	1.2	6.7	2.5	1.1	6.5	2.5	1.0	6.4	2.4	0.9	6.2	2.4	0.9
	30	6.4	2.6	1.2	6.2	2.5	1.1	6.0	2.5	1.0	5.8	2.5	1.0	5.6	2.5	0.9
	40	6.0	2.6	1.3	5.7	2.6	1.1	5.5	2.6	1.1	5.3	2.6	1.0	5.1	2.5	0.9
300 x 63	10	7.9	2.8	1.4	7.6	2.7	1.3	7.4	2.7	1.2	7.2	2.7	1.1	7.0	2.7	1.1
	20	7.4	2.8	1.5	7.2	2.8	1.3	7.0	2.8	1.2	6.8	2.8	1.1	6.7	2.7	1.1
	30	6.8	2.9	1.5	6.6	2.9	1.4	6.4	2.9	1.3	6.3	2.8	1.2	6.1	2.8	1.1
	40	6.4	3.0	1.5	6.2	3.0	1.4	6.0	2.9	1.3	5.8	2.8	1.2	5.7	2.8	1.1
300 x 75	10	8.3	2.9	1.6	8.0	2.9	1.4	7.7	2.9	1.3	7.5	2.9	1.2	7.3	2.9	1.2
	20	7.6	3.0	1.6	7.4	3.0	1.5	7.2	3.0	1.4	7.1	2.9	1.3	6.9	2.9	1.2
	30	7.1	3.1	1.7	6.9	3.1	1.5	6.7	3.0	1.4	6.5	3.0	1.3	6.4	3.0	1.2
	40	6.7	3.2	1.7	6.5	3.1	1.5	6.3	3.1	1.4	6.1	3.0	1.3	6.0	2.9	1.3
360 x 63	10	9.1	3.4	1.7	8.8	3.3	1.5	8.5	3.3	1.4	8.2	3.3	1.3	8.0	3.3	1.2
	20	8.4	3.5	1.7	8.2	3.4	1.5	8.0	3.4	1.4	7.8	3.3	1.3	7.6	3.3	1.3
	30	7.8	3.6	1.8	7.5	3.5	1.6	7.3	3.5	1.5	7.1	3.4	1.4	7.0	3.4	1.3
	40	7.3	3.5	1.8	7.1	3.4	1.6	6.9	3.3	1.5	6.7	3.3	1.4	6.6	3.2	1.3
400 x 63	10	9.9	3.8	1.8	9.5	3.7	1.6	9.2	3.7	1.5	8.9	3.7	1.4	8.7	3.7	1.3
	20	9.0	3.9	1.9	8.8	3.8	1.7	8.6	3.8	1.6	8.4	3.8	1.5	8.2	3.7	1.4
	30	8.4	4.0	1.9	8.1	3.9	1.7	7.9	3.8	1.6	7.7	3.7	1.5	7.5	3.6	1.4
	40	7.9	3.8	2.0	7.6	3.7	1.8	7.4	3.6	1.6	7.2	3.5	1.5	7.1	3.4	1.4
400 x 75	10	10.3	4.0	2.0	9.9	4.0	1.8	9.6	3.9	1.7	9.3	3.9	1.6	9.1	3.9	1.5
	20	9.3	4.2	2.1	9.0	4.1	1.9	8.8	4.1	1.7	8.6	4.0	1.6	8.5	4.0	1.5
	30	8.6	4.2	2.1	8.4	4.1	1.9	8.2	4.0	1.8	8.0	3.9	1.6	7.8	3.8	1.5
	40	8.2	4.0	2.2	7.9	3.8	2.0	7.7	3.7	1.8	7.5	3.6	1.7	7.4	3.6	1.6
450 x 63	10	10.8	4.3	2.0	10.4	4.2	1.8	10.0	4.2	1.7	9.7	4.2	1.6	9.5	4.1	1.5
	20	9.8	4.4	2.1	9.5	4.4	1.9	9.3	4.3	1.7	9.1	4.3	1.6	8.9	4.2	1.5
	30	9.1	4.4	2.1	8.8	4.3	1.9	8.6	4.2	1.8	8.4	4.1	1.6	8.2	4.0	1.5
	40	8.6	4.2	2.2	8.3	4.0	1.9	8.1	3.9	1.8	7.9	3.8	1.7	7.7	3.7	1.6
525 x 75	10	-	-	-	11.9	5.4	2.3	11.7	5.3	2.1	11.4	5.2	2.0	11.1	5.2	1.8
	20	11.1	5.4	2.6	10.8	5.2	2.3	10.6	5.1	2.2	10.4	5.0	2.0	10.2	4.9	1.9
	30	10.4	5.0	2.7	10.1	4.9	2.4	9.9	4.8	2.2	9.7	4.7	2.1	9.5	4.6	1.9
	40	9.9	4.8	2.7	9.6	4.6	2.5	9.3	4.5	2.3	9.1	4.4	2.1	8.9	4.3	2.0

Overhang O/H<sup>1</sup> applies only where the rafter is not birdsmouthed.

Overhang O/H<sup>2</sup> applies for birdsmouths not exceeding D/3 - see page 46.

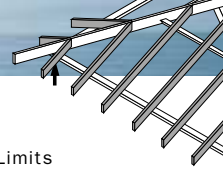

# RAFTERS

Widely Spaced - Design Wind Speed 41 m/s

Design Deflection Limits  
 D.L. L.L.  
 SPAN/300 SPAN/300  
 OR 20 mm OR 12.5 mm

HYSPAN SECTION D X B (mm)	ROOF MASS kg/m <sup>2</sup>	MAXIMUM RAFTER SPACING (m)														
		1.8			2.1			2.4			2.7			3.0		
		MAXIMUM SPAN AND OVERHANG 'O/H' (mm)														
		SPAN	O/H <sup>1</sup>	O/H <sup>2</sup>	SPAN	O/H <sup>1</sup>	O/H <sup>2</sup>	SPAN	O/H <sup>1</sup>	O/H <sup>2</sup>	SPAN	O/H <sup>1</sup>	O/H <sup>2</sup>	SPAN	O/H <sup>1</sup>	O/H <sup>2</sup>
150 x 45	10	3.5	1.3	0.5	3.3	1.3	0.5	3.0	1.3	0.4	2.9	1.2	0.4	2.7	1.1	0.4
	20	3.6	1.3	0.5	3.4	1.3	0.5	3.1	1.3	0.4	3.0	1.2	0.4	2.8	1.2	0.4
	30	3.3	1.3	0.5	3.2	1.3	0.5	3.0	1.3	0.4	2.9	1.2	0.4	2.8	1.2	0.4
	40	3.0	1.4	0.5	2.9	1.3	0.5	2.8	1.3	0.5	2.7	1.3	0.4	2.6	1.2	0.4
150 x 63	10	4.3	1.4	0.6	4.0	1.4	0.6	3.7	1.4	0.5	3.5	1.4	0.5	3.3	1.4	0.5
	20	4.2	1.4	0.6	4.0	1.4	0.6	3.8	1.4	0.5	3.6	1.4	0.5	3.5	1.4	0.5
	30	3.7	1.5	0.6	3.5	1.4	0.6	3.4	1.4	0.5	3.3	1.4	0.5	3.1	1.4	0.5
	40	3.4	1.5	0.7	3.2	1.5	0.6	3.1	1.5	0.6	3.0	1.5	0.5	2.9	1.4	0.5
150 x 75	10	4.7	1.4	0.7	4.4	1.4	0.6	4.1	1.5	0.6	3.9	1.5	0.5	3.7	1.5	0.5
	20	4.4	1.5	0.7	4.2	1.5	0.6	4.0	1.5	0.6	3.9	1.5	0.6	3.8	1.4	0.5
	30	3.9	1.5	0.7	3.7	1.5	0.6	3.6	1.5	0.6	3.4	1.5	0.6	3.3	1.5	0.5
	40	3.6	1.6	0.7	3.4	1.6	0.7	3.3	1.6	0.6	3.1	1.6	0.6	3.0	1.5	0.5
170 x 36	10	3.2	1.4	0.5	2.9	1.4	0.5	2.7	1.3	0.4	2.6	1.2	0.4	2.5	1.2	0.4
	20	3.3	1.4	0.5	3.0	1.4	0.5	2.8	1.3	0.4	2.7	1.2	0.4	2.5	1.2	0.4
	30	3.4	1.4	0.5	3.1	1.4	0.5	2.9	1.3	0.4	2.8	1.3	0.4	2.6	1.2	0.4
	40	3.2	1.4	0.5	3.0	1.4	0.5	2.9	1.4	0.4	2.8	1.3	0.4	2.7	1.2	0.4
170 x 45	10	3.9	1.5	0.6	3.6	1.5	0.5	3.4	1.5	0.5	3.2	1.4	0.4	3.0	1.3	0.4
	20	4.0	1.4	0.6	3.7	1.4	0.5	3.5	1.4	0.5	3.3	1.4	0.5	3.1	1.3	0.4
	30	3.8	1.5	0.6	3.6	1.5	0.5	3.4	1.5	0.5	3.3	1.4	0.5	3.2	1.3	0.4
	40	3.4	1.5	0.6	3.3	1.5	0.5	3.1	1.5	0.5	3.0	1.4	0.5	2.9	1.3	0.4
200 x 36	10	3.6	1.7	0.6	3.3	1.7	0.5	3.1	1.5	0.5	2.9	1.4	0.4	2.8	1.4	0.4
	20	3.7	1.7	0.6	3.4	1.7	0.5	3.2	1.6	0.5	3.0	1.5	0.4	2.9	1.4	0.4
	30	3.8	1.6	0.6	3.5	1.7	0.5	3.3	1.6	0.5	3.1	1.5	0.5	3.0	1.4	0.4
	40	3.8	1.6	0.6	3.6	1.6	0.5	3.4	1.6	0.5	3.2	1.5	0.5	3.1	1.4	0.4
200 x 45	10	4.5	1.7	0.6	4.1	1.7	0.6	3.9	1.7	0.5	3.6	1.6	0.5	3.4	1.5	0.5
	20	4.6	1.7	0.7	4.3	1.7	0.6	4.0	1.7	0.6	3.8	1.6	0.5	3.6	1.5	0.5
	30	4.4	1.7	0.7	4.2	1.7	0.6	4.0	1.7	0.6	3.9	1.7	0.5	3.7	1.6	0.5
	40	4.0	1.8	0.7	3.8	1.8	0.6	3.7	1.7	0.6	3.5	1.7	0.5	3.4	1.6	0.5
240 x 45	10	5.2	2.1	0.7	4.8	2.1	0.7	4.5	2.1	0.6	4.2	1.9	0.6	4.0	1.8	0.5
	20	5.3	2.0	0.8	4.9	2.1	0.7	4.6	2.1	0.6	4.3	2.0	0.6	4.1	1.8	0.6
	30	5.2	2.1	0.8	5.0	2.0	0.7	4.8	2.0	0.6	4.5	2.0	0.6	4.3	1.9	0.6
	40	4.8	2.1	0.8	4.6	2.1	0.7	4.4	2.1	0.7	4.2	2.0	0.6	4.1	1.9	0.6
240 x 63	10	6.7	2.2	0.9	6.5	2.2	0.8	6.0	2.2	0.8	5.7	2.2	0.7	5.4	2.2	0.7
	20	6.3	2.2	0.9	6.2	2.2	0.8	6.0	2.2	0.8	5.8	2.2	0.7	5.6	2.2	0.7
	30	5.8	2.3	0.9	5.5	2.3	0.9	5.3	2.3	0.8	5.1	2.3	0.7	5.0	2.2	0.7
	40	5.3	2.4	1.0	5.1	2.3	0.9	4.9	2.3	0.8	4.7	2.3	0.8	4.6	2.3	0.7

Overhang O/H<sup>1</sup> applies only where the rafter is not birdsmouthed.  
 Overhang O/H<sup>2</sup> applies for birdsmouths not exceeding D/3 - see page 46.

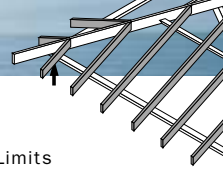

# RAFTERS

Widely Spaced - Design Wind Speed 41 m/s

Design Deflection Limits  
 D.L. L.L.  
 SPAN/300 SPAN/300  
 OR 20 mm OR 12.5 mm

HYSPAN SECTION D X B (mm)	ROOF MASS kg/m <sup>2</sup>	MAXIMUM RAFTER SPACING (m)														
		1.8			2.1			2.4			2.7			3.0		
		MAXIMUM SPAN AND OVERHANG 'O/H' (mm)														
		SPAN	O/H <sup>1</sup>	O/H <sup>2</sup>	SPAN	O/H <sup>1</sup>	O/H <sup>2</sup>	SPAN	O/H <sup>1</sup>	O/H <sup>2</sup>	SPAN	O/H <sup>1</sup>	O/H <sup>2</sup>	SPAN	O/H <sup>1</sup>	O/H <sup>2</sup>
300 x 45	10	5.9	2.6	0.9	5.5	2.6	0.8	5.1	2.6	0.8	4.8	2.4	0.7	4.6	2.3	0.7
	20	6.1	2.6	0.9	5.7	2.6	0.8	5.3	2.6	0.8	5.0	2.5	0.7	4.7	2.3	0.7
	30	6.3	2.6	0.9	5.9	2.6	0.8	5.5	2.6	0.8	5.1	2.5	0.7	4.9	2.3	0.7
	40	6.0	2.6	0.9	5.7	2.6	0.9	5.5	2.6	0.8	5.3	2.5	0.7	5.1	2.4	0.7
300 x 63	10	7.9	2.8	1.1	7.6	2.7	1.0	7.1	2.8	0.9	6.7	2.8	0.9	6.3	2.7	0.8
	20	7.4	2.8	1.1	7.2	2.8	1.0	7.0	2.8	0.9	6.8	2.8	0.9	6.5	2.7	0.8
	30	6.8	2.9	1.1	6.6	2.9	1.0	6.4	2.9	1.0	6.3	2.8	0.9	6.1	2.8	0.8
	40	6.4	3.0	1.1	6.2	2.9	1.0	6.0	2.9	1.0	5.8	2.8	0.9	5.7	2.8	0.8
300 x 75	10	8.3	2.9	1.2	8.0	2.9	1.1	7.7	2.9	1.0	7.5	2.9	1.0	7.3	2.9	0.9
	20	7.6	3.0	1.2	7.4	3.0	1.1	7.2	3.0	1.0	7.1	2.9	1.0	6.9	2.9	0.9
	30	7.1	3.1	1.2	6.9	3.1	1.1	6.7	3.0	1.1	6.5	3.0	1.0	6.4	3.0	0.9
	40	6.7	3.2	1.3	6.5	3.1	1.2	6.3	3.1	1.1	6.1	3.0	1.0	6.0	2.9	0.9
360 x 63	10	9.1	3.4	1.3	8.5	3.4	1.2	7.9	3.4	1.1	7.4	3.4	1.0	7.0	3.3	0.9
	20	8.4	3.5	1.3	8.2	3.4	1.2	8.0	3.4	1.1	7.7	3.4	1.0	7.3	3.3	0.9
	30	7.8	3.5	1.3	7.5	3.5	1.2	7.3	3.5	1.1	7.1	3.4	1.0	7.0	3.3	1.0
	40	7.3	3.5	1.3	7.1	3.4	1.2	6.9	3.3	1.1	6.7	3.3	1.0	6.6	3.2	1.0
400 x 63	10	9.6	3.8	1.4	8.9	3.8	1.3	8.3	3.8	1.2	7.8	3.8	1.1	7.4	3.6	1.0
	20	9.0	3.9	1.4	8.8	3.8	1.3	8.6	3.8	1.2	8.1	3.8	1.1	7.6	3.7	1.0
	30	8.4	4.0	1.4	8.1	3.9	1.3	7.9	3.8	1.2	7.7	3.7	1.1	7.5	3.6	1.0
	40	7.9	3.8	1.4	7.6	3.7	1.3	7.4	3.6	1.2	7.2	3.5	1.1	7.1	3.4	1.1
400 x 75	10	10.3	4.0	1.5	9.9	4.0	1.4	9.6	3.9	1.3	9.3	3.9	1.2	8.8	3.9	1.1
	20	9.3	4.1	1.6	9.0	4.1	1.4	8.8	4.0	1.3	8.6	4.0	1.2	8.5	4.0	1.1
	30	8.6	4.2	1.6	8.4	4.1	1.4	8.2	4.0	1.3	8.0	3.9	1.2	7.8	3.8	1.2
	40	8.2	4.0	1.6	7.9	3.8	1.5	7.7	3.7	1.4	7.5	3.6	1.3	7.4	3.6	1.2
450 x 63	10	10.1	4.4	1.5	9.3	4.4	1.4	8.7	4.4	1.3	8.1	4.3	1.2	7.7	4.1	1.1
	20	9.8	4.4	1.5	9.5	4.3	1.4	9.0	4.3	1.3	8.4	4.2	1.2	8.0	4.0	1.1
	30	9.1	4.4	1.6	8.8	4.3	1.4	8.6	4.2	1.3	8.4	4.1	1.2	8.2	4.0	1.2
	40	8.6	4.2	1.6	8.3	4.0	1.5	8.1	3.9	1.3	7.9	3.8	1.3	7.7	3.7	1.2
525 x 75	10	-	-	-	11.9	5.3	1.8	11.2	5.3	1.6	10.6	5.3	1.5	10.0	5.1	1.4
	20	11.1	5.4	1.9	10.8	5.2	1.8	10.6	5.1	1.6	10.4	5.0	1.5	10.2	4.9	1.4
	30	10.4	5.0	2.0	10.1	4.9	1.8	9.9	4.8	1.7	9.7	4.7	1.6	9.5	4.6	1.5
	40	9.9	4.8	2.0	9.6	4.6	1.8	9.3	4.5	1.7	9.1	4.4	1.6	8.9	4.3	1.5

Overhang O/H<sup>1</sup> applies only where the rafter is not birdsmouthed.

Overhang O/H<sup>2</sup> applies for birdsmouths not exceeding D/3 - see page 46.

# ROOF BEAMS

Ridge, Intermediate, Eave and Bressummer Beams

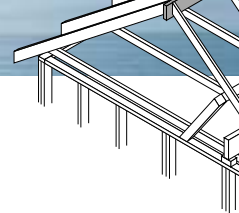

## DETERMINATION OF ROOF LOAD WIDTH 'RLW'.

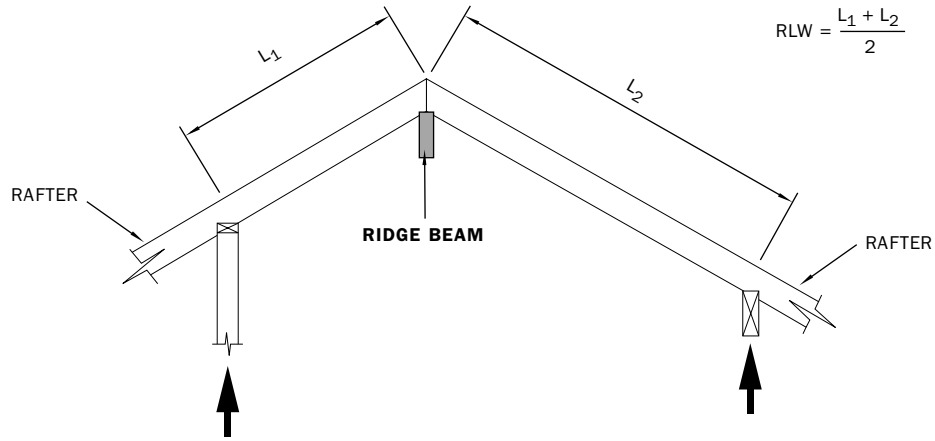

**RIDGE BEAM**

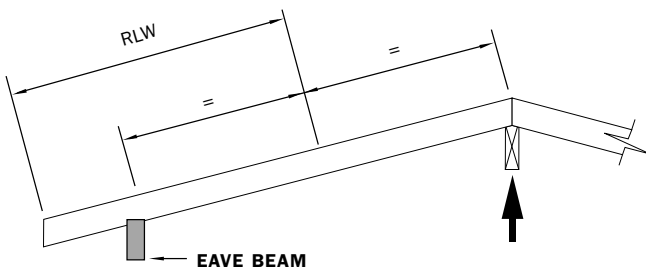

**EAVE BEAM**

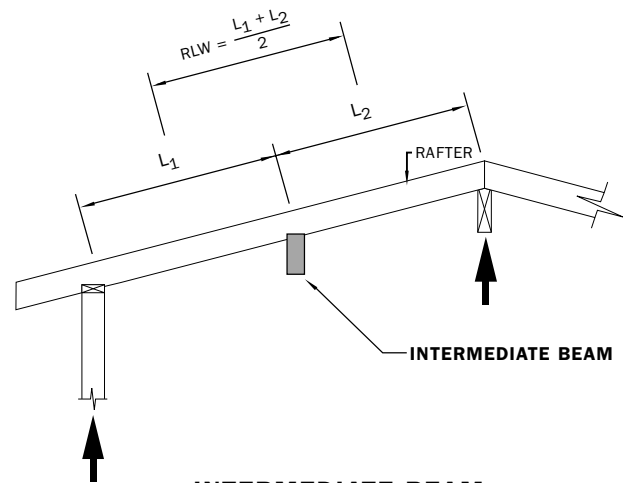

**INTERMEDIATE BEAM**

FOR OTHER ROOF CONSTRUCTIONS ROOF LOAD WIDTH FOR EAVES BEAMS AND BRESSUMMERS MAY BE DETERMINED AS FOR LINTELS AS GIVEN ON PAGE 24.

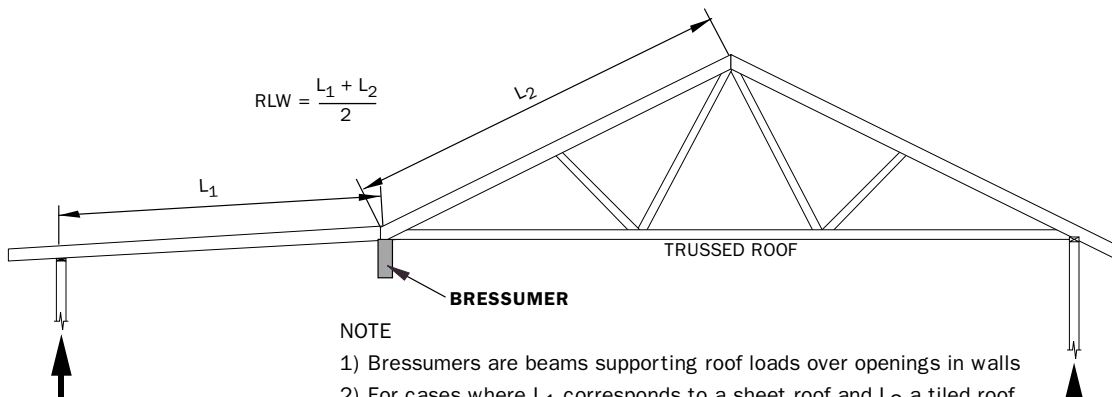

**NOTE**

- 1) Bressumers are beams supporting roof loads over openings in walls
- 2) For cases where  $L_1$  corresponds to a sheet roof and  $L_2$  a tiled roof (including ceiling), then using the tile roof table take,

$$RLW = L_2 + \frac{40}{90} (L_1).$$

**BRESSUMER BEAM**

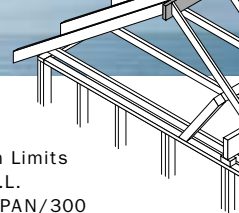

# ROOF BEAMS

Ridge, Intermediate, Eave and Bressummer Beams

Design Deflection Limits  
 D.L. L.L.  
 SPAN/300 SPAN/300  
 OR 20 mm OR 12.5 mm

HYSPAN SECTION D X B (mm)	SHEET ROOF AND CEILING											
	ROOF LOAD WIDTH 'RLW' (m)											
	1.8	2.1	2.4	2.7	3.0	3.3	3.6	3.9	4.2	4.8	5.4	6.0
	MAXIMUM SINGLE SPAN (m)											
150 x 36	2.8	2.7	2.6	2.5	2.4	2.3	2.3	2.2	2.1	2.0	1.9	1.8
150 x 45	3.0	2.9	2.8	2.7	2.6	2.5	2.4	2.4	2.3	2.2	2.1	2.1
170 x 36	3.2	3.0	2.9	2.8	2.7	2.6	2.5	2.4	2.3	2.2	2.0	1.9
170 x 45	3.4	3.3	3.1	3.0	2.9	2.8	2.8	2.7	2.6	2.5	2.4	2.3
200 x 36	3.8	3.6	3.4	3.2	3.1	2.9	2.8	2.7	2.6	2.4	2.3	2.2
200 x 45	4.0	3.8	3.7	3.5	3.4	3.3	3.2	3.2	3.1	2.9	2.8	2.7
200 x 63	4.5	4.3	4.1	3.9	3.8	3.7	3.6	3.5	3.4	3.3	3.2	3.1
240 x 36	4.5	4.2	3.9	3.7	3.5	3.3	3.2	3.0	2.9	2.7	2.6	2.4
240 x 45	4.8	4.6	4.4	4.2	4.1	4.0	3.9	3.8	3.7	3.5	3.3	3.2
240 x 63	5.3	5.1	4.9	4.7	4.6	4.4	4.3	4.2	4.1	3.9	3.8	3.7
300 x 45	6.0	5.7	5.5	5.3	5.1	4.9	4.6	4.5	4.3	4.0	3.8	3.6
300 x 63	6.4	6.2	6.0	5.8	5.7	5.5	5.4	5.2	5.1	4.9	4.7	4.6
300 x 75	6.7	6.5	6.3	6.1	6.0	5.8	5.7	5.5	5.4	5.2	5.0	4.8
360 x 63	7.3	7.1	6.9	6.7	6.6	6.4	6.3	6.2	6.1	5.9	5.6	5.5
400 x 45	6.9	6.4	5.9	5.6	5.3	5.0	4.8	4.6	4.4	4.2	3.9	3.7
400 x 63	7.9	7.6	7.4	7.2	7.1	6.9	6.8	6.7	6.6	6.4	6.1	5.8
400 x 75	8.2	7.9	7.7	7.5	7.4	7.2	7.1	6.9	6.8	6.6	6.4	6.3
450 x 63	8.6	8.3	8.1	7.9	7.7	7.5	7.4	7.3	7.1	6.8	6.4	6.0
525 x 75	9.9	9.6	9.3	9.1	8.9	8.7	8.6	8.4	8.3	8.1	7.9	7.7
	MAXIMUM CONTINUOUS SPAN (m)											
150 x 36	3.5	3.3	3.2	3.1	2.9	2.8	2.6	2.5	2.4	2.3	2.2	2.0
150 x 45	3.8	3.6	3.4	3.3	3.2	3.1	3.0	2.8	2.7	2.6	2.4	2.3
170 x 36	4.0	3.8	3.6	3.4	3.3	3.1	3.0	2.9	2.8	2.6	2.4	2.3
170 x 45	4.2	4.0	3.9	3.7	3.6	3.5	3.4	3.2	3.1	2.9	2.7	2.6
200 x 36	4.6	4.3	4.1	3.9	3.7	3.5	3.4	3.3	3.2	3.0	2.8	2.7
200 x 45	5.0	4.7	4.5	4.4	4.2	4.1	3.9	3.8	3.7	3.4	3.2	3.0
200 x 63	5.5	5.3	5.1	4.9	4.7	4.6	4.5	4.3	4.2	4.0	3.8	3.6
240 x 36	5.2	4.8	4.6	4.3	4.1	4.0	3.8	3.7	3.6	3.4	3.2	3.1
240 x 45	5.9	5.7	5.4	5.2	5.0	4.8	4.6	4.4	4.3	4.0	3.8	3.6
240 x 63	6.4	6.2	6.0	5.8	5.6	5.5	5.3	5.2	5.1	4.9	4.6	4.3
300 x 45	7.0	6.8	6.4	6.0	5.8	5.5	5.3	5.1	4.9	4.7	4.4	4.2
300 x 63	7.5	7.3	7.1	6.9	6.7	6.6	6.5	6.3	6.2	6.0	5.7	5.4
300 x 75	7.8	7.6	7.4	7.2	7.0	6.9	6.7	6.6	6.5	6.3	6.1	5.9
360 x 63	-	-	8.1	7.9	7.7	7.5	7.4	7.2	7.1	6.9	6.5	6.2
400 x 45	8.2	7.7	7.3	6.9	6.6	6.4	6.2	6.0	5.8	5.5	5.2	4.9
400 x 63	-	-	-	-	-	-	8.0	7.8	7.7	7.4	7.0	6.7
400 x 75	-	-	-	-	-	-	-	-	8.0	7.8	7.6	7.4

FOR DETERMINATION OF ROOF LOAD WIDTH 'RLW' FOR ROOF BEAMS - SEE THE DIAGRAMS ON PAGE 57.

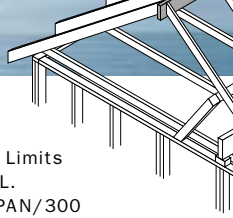

# ROOF BEAMS

Ridge, Intermediate, Eave and Bressummer Beams

Design Deflection Limits  
 D.L. L.L.  
 SPAN/300 SPAN/300  
 OR 20 mm OR 12.5 mm

DESIGN WIND SPEED 41 m/s

HYSPAN SECTION D X B (mm)	TILE ROOF AND CEILING (90 kg/m <sup>2</sup> )											
	ROOF LOAD WIDTH 'RLW' (m)											
	1.8	2.1	2.4	2.7	3.0	3.3	3.6	3.9	4.2	4.8	5.4	6.0
	MAXIMUM SINGLE SPAN (m)											
150 x 36	2.2	2.1	2.0	1.9	1.8	1.8	1.7	1.7	1.6	1.6	1.5	1.5
150 x 45	2.3	2.2	2.1	2.1	2.0	1.9	1.9	1.8	1.8	1.7	1.6	1.6
170 x 36	2.5	2.3	2.2	2.2	2.1	2.0	2.0	1.9	1.9	1.8	1.7	1.6
170 x 45	2.7	2.5	2.4	2.3	2.2	2.2	2.1	2.1	2.0	1.9	1.9	1.8
200 x 36	2.9	2.8	2.6	2.5	2.5	2.4	2.3	2.3	2.2	2.0	1.9	1.8
200 x 45	3.1	3.0	2.8	2.7	2.6	2.6	2.5	2.4	2.4	2.3	2.2	2.1
200 x 63	3.5	3.3	3.2	3.0	2.9	2.9	2.8	2.7	2.6	2.5	2.4	2.3
240 x 36	3.5	3.3	3.2	3.0	2.9	2.7	2.6	2.5	2.4	2.3	2.1	2.0
240 x 45	3.7	3.6	3.4	3.3	3.2	3.1	3.0	2.9	2.8	2.7	2.6	2.5
240 x 63	4.2	4.0	3.8	3.6	3.5	3.4	3.3	3.2	3.2	3.0	2.9	2.8
300 x 45	4.6	4.4	4.2	4.1	3.9	3.8	3.7	3.6	3.5	3.4	3.3	3.1
300 x 63	5.2	4.9	4.7	4.5	4.4	4.3	4.1	4.0	3.9	3.8	3.6	3.5
300 x 75	5.5	5.2	5.0	4.8	4.6	4.5	4.4	4.3	4.2	4.0	3.8	3.7
360 x 63	6.1	5.9	5.6	5.4	5.3	5.1	5.0	4.8	4.7	4.5	4.4	4.2
400 x 45	6.1	5.9	5.6	5.4	5.1	4.9	4.7	4.5	4.3	4.1	3.8	3.6
400 x 63	6.6	6.4	6.2	6.0	5.8	5.7	5.5	5.4	5.2	5.0	4.8	4.7
400 x 75	6.9	6.6	6.4	6.3	6.1	6.0	5.8	5.7	5.5	5.3	5.1	4.9
450 x 63	7.2	7.0	6.8	6.6	6.4	6.3	6.1	6.0	5.9	5.6	5.4	5.3
525 x 75	8.4	8.1	7.9	7.7	7.5	7.3	7.2	7.0	6.9	6.7	6.5	6.3
	MAXIMUM CONTINUOUS SPAN (m)											
150 x 36	2.7	2.6	2.5	2.4	2.3	2.2	2.1	2.1	2.0	2.0	1.9	1.8
150 x 45	2.9	2.8	2.6	2.5	2.5	2.4	2.3	2.2	2.2	2.1	2.0	2.0
170 x 36	3.0	2.9	2.8	2.7	2.6	2.5	2.4	2.4	2.3	2.2	2.1	2.0
170 x 45	3.3	3.1	3.0	2.9	2.8	2.7	2.6	2.5	2.5	2.4	2.3	2.2
200 x 36	3.6	3.4	3.3	3.1	3.0	2.9	2.9	2.8	2.7	2.6	2.5	2.4
200 x 45	3.9	3.7	3.5	3.4	3.3	3.2	3.1	3.0	2.9	2.8	2.7	2.6
200 x 63	4.3	4.1	3.9	3.8	3.6	3.5	3.4	3.3	3.3	3.1	3.0	2.9
240 x 36	4.3	4.1	3.9	3.8	3.6	3.5	3.4	3.3	3.2	3.0	2.8	2.7
240 x 45	4.6	4.4	4.2	4.0	3.9	3.8	3.7	3.6	3.5	3.4	3.2	3.1
240 x 63	5.1	4.9	4.7	4.5	4.4	4.2	4.1	4.0	3.9	3.7	3.6	3.5
300 x 45	5.7	5.5	5.2	5.0	4.9	4.7	4.6	4.5	4.3	4.1	3.9	3.7
300 x 63	6.3	6.1	5.8	5.6	5.4	5.3	5.1	5.0	4.9	4.7	4.5	4.3
300 x 75	6.5	6.3	6.1	5.9	5.7	5.6	5.4	5.3	5.2	4.9	4.8	4.6
360 x 63	7.2	6.9	6.7	6.5	6.4	6.2	6.1	6.0	5.8	5.6	5.4	5.2
400 x 45	6.8	6.5	6.1	5.9	5.6	5.4	5.2	5.1	4.9	4.7	4.5	4.3
400 x 63	7.8	7.5	7.3	7.1	6.9	6.7	6.6	6.5	6.4	6.2	6.0	5.7
400 x 75	8.1	7.8	7.6	7.4	7.2	7.0	6.9	6.7	6.6	6.4	6.2	6.1

FOR DETERMINATION OF ROOF LOAD WIDTH 'RLW' FOR ROOF BEAMS - SEE THE DIAGRAMS ON PAGE 57.

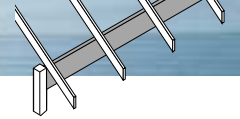

# VERANDAH BEAMS

Design Wind Speed 33 m/s

Design Deflection Limits  
 D.L. L.L.  
 SPAN/300 SPAN/300  
 OR 15 mm OR 15 mm

HYSPAN SECTION D X B (mm)	ROOF MASS kg/m <sup>2</sup>	SINGLE SPAN							CONTINUOUS SPAN						
		ROOF LOAD WIDTH 'RLW' (m)													
		0.9	1.2	1.5	1.8	2.1	2.4	2.7	0.9	1.2	1.5	1.8	2.1	2.4	2.7
MAXIMUM SPAN (m)															
130 x 36	10	3.2	3.1	3.1	3.0	3.0	2.9	2.9	3.8	3.7	3.6	3.5	3.4	3.4	3.2
	20	3.2	3.1	3.1	3.0	2.9	2.8	2.7	3.8	3.7	3.6	3.5	3.4	3.4	3.3
	40	3.1	2.8	2.6	2.5	2.3	2.2	2.2	3.8	3.5	3.2	3.0	2.9	2.8	2.7
	75	2.5	2.3	2.1	2.0	1.9	1.8	1.8	3.1	2.8	2.6	2.5	2.4	2.3	2.2
	90	2.4	2.2	2.0	1.9	1.8	1.7	1.7	2.9	2.7	2.5	2.3	2.2	2.1	2.0
130 x 45	10	3.6	3.5	3.4	3.3	3.3	3.2	3.1	4.2	4.1	4.0	3.9	3.8	3.7	3.6
	20	3.6	3.5	3.4	3.3	3.1	3.0	2.9	4.2	4.1	4.0	3.9	3.8	3.7	3.6
	40	3.3	3.0	2.8	2.6	2.5	2.4	2.3	4.0	3.7	3.5	3.3	3.1	3.0	2.9
	75	2.7	2.5	2.3	2.2	2.1	2.0	1.9	3.3	3.0	2.8	2.7	2.5	2.4	2.3
	90	2.5	2.3	2.2	2.0	1.9	1.9	1.8	3.1	2.9	2.7	2.5	2.4	2.3	2.2
130 x 63	10	4.2	4.0	3.9	3.8	3.8	3.7	3.6	4.8	4.6	4.6	4.5	4.4	4.3	4.2
	20	4.2	4.0	3.8	3.6	3.5	3.3	3.2	4.8	4.6	4.6	4.5	4.3	4.1	4.0
	40	3.6	3.3	3.1	2.9	2.8	2.7	2.6	4.5	4.1	3.8	3.6	3.5	3.3	3.2
	75	3.0	2.7	2.5	2.4	2.3	2.2	2.1	3.7	3.4	3.2	3.0	2.8	2.7	2.6
	90	2.8	2.6	2.4	2.3	2.2	2.1	2.0	3.5	3.2	3.0	2.8	2.7	2.6	2.5
150 x 36	10	3.9	3.8	3.7	3.6	3.6	3.5	3.4	4.6	4.5	4.3	4.2	4.1	3.8	3.6
	20	3.9	3.8	3.7	3.5	3.4	3.2	3.1	4.6	4.5	4.3	4.2	4.1	4.0	3.8
	40	3.5	3.2	3.0	2.8	2.7	2.6	2.5	4.3	4.0	3.7	3.5	3.3	3.2	3.1
	75	2.9	2.6	2.5	2.3	2.2	2.1	2.0	3.6	3.3	3.0	2.9	2.7	2.6	2.5
	90	2.7	2.5	2.3	2.2	2.1	2.0	1.9	3.4	3.1	2.9	2.7	2.6	2.5	2.3
150 x 45	10	4.3	4.2	4.1	4.0	3.9	3.8	3.8	4.9	4.8	4.7	4.6	4.5	4.4	4.3
	20	4.3	4.2	4.0	3.8	3.6	3.4	3.3	4.9	4.8	4.7	4.6	4.4	4.3	4.1
	40	3.8	3.4	3.2	3.0	2.9	2.8	2.7	4.6	4.3	4.0	3.8	3.6	3.4	3.3
	75	3.1	2.8	2.6	2.5	2.4	2.3	2.2	3.8	3.5	3.3	3.1	2.9	2.8	2.7
	90	2.9	2.7	2.5	2.3	2.2	2.1	2.1	3.6	3.3	3.1	2.9	2.8	2.6	2.5
150 x 63	10	4.9	4.8	4.7	4.6	4.5	4.4	4.3	5.4	5.3	5.2	5.1	5.0	4.9	4.8
	20	4.9	4.6	4.4	4.2	4.0	3.8	3.7	5.4	5.3	5.2	5.0	4.8	4.7	4.5
	40	4.2	3.8	3.6	3.4	3.2	3.1	3.0	5.0	4.7	4.4	4.2	4.0	3.8	3.7
	75	3.4	3.1	2.9	2.8	2.6	2.5	2.4	4.3	3.9	3.6	3.4	3.3	3.1	3.0
	90	3.3	3.0	2.8	2.6	2.5	2.4	2.3	4.0	3.7	3.4	3.2	3.1	2.9	2.8
170 x 36	10	4.6	4.5	4.4	4.3	4.2	4.1	4.0	5.1	5.0	4.9	4.8	4.5	4.2	4.0
	20	4.6	4.5	4.2	4.0	3.8	3.6	3.5	5.1	5.0	4.9	4.8	4.6	4.5	4.3
	40	4.0	3.6	3.4	3.2	3.0	2.9	2.8	4.8	4.5	4.2	4.0	3.8	3.6	3.5
	75	3.3	3.0	2.8	2.6	2.5	2.4	2.3	4.0	3.7	3.4	3.2	3.1	2.9	2.8
	90	3.1	2.8	2.6	2.5	2.3	2.2	2.2	3.8	3.5	3.2	3.0	2.9	2.7	2.6
170 x 45	10	4.9	4.8	4.7	4.6	4.6	4.5	4.4	5.5	5.4	5.2	5.1	5.1	5.0	4.9
	20	4.9	4.7	4.5	4.2	4.1	3.9	3.8	5.5	5.4	5.2	5.0	4.9	4.7	4.6
	40	4.2	3.9	3.6	3.4	3.3	3.1	3.0	5.0	4.7	4.5	4.2	4.0	3.9	3.7
	75	3.5	3.2	3.0	2.8	2.7	2.6	2.5	4.3	4.0	3.7	3.5	3.3	3.2	3.0
	90	3.3	3.0	2.8	2.7	2.5	2.4	2.3	4.1	3.7	3.5	3.3	3.1	3.0	2.9
170 x 63	10	5.5	5.3	5.2	5.1	5.0	5.0	4.9	6.1	5.9	5.8	5.7	5.6	5.5	5.4
	20	5.3	5.0	4.8	4.6	4.5	4.3	4.2	6.1	5.9	5.6	5.4	5.3	5.1	5.0
	40	4.6	4.3	4.0	3.8	3.6	3.5	3.4	5.4	5.1	4.9	4.7	4.5	4.3	4.2
	75	3.9	3.6	3.3	3.1	3.0	2.9	2.8	4.7	4.4	4.1	3.9	3.7	3.5	3.4
	90	3.7	3.4	3.1	3.0	2.8	2.7	2.6	4.5	4.2	3.9	3.7	3.5	3.3	3.2





# VERANDAH BEAMS

Design Wind Speed 33 m/s

Design Deflection Limits  
 D.L. L.L.  
 SPAN/300 SPAN/300  
 OR 15 mm OR 15 mm

HYSPAN SECTION D X B (mm)	ROOF MASS kg/m <sup>2</sup>	SINGLE SPAN							CONTINUOUS SPAN						
		ROOF LOAD WIDTH 'RLW' (m)													
		0.9	1.2	1.5	1.8	2.1	2.4	2.7	0.9	1.2	1.5	1.8	2.1	2.4	2.7
MAXIMUM SPAN (m)															
200 x 36	10	5.4	5.2	5.1	5.0	4.9	4.8	4.5	6.0	5.8	5.7	5.5	5.1	4.8	4.5
	20	5.3	5.0	4.8	4.6	4.4	4.3	4.1	6.0	5.8	5.6	5.4	5.2	5.1	4.9
	40	4.6	4.3	4.0	3.8	3.6	3.4	3.3	5.4	5.1	4.8	4.6	4.4	4.2	4.1
	75	3.8	3.5	3.3	3.1	2.9	2.8	2.7	4.7	4.3	4.0	3.8	3.6	3.3	3.2
	90	3.6	3.3	3.1	2.9	2.8	2.6	2.5	4.5	4.1	3.8	3.5	3.3	3.1	2.9
200 x 45	10	5.7	5.6	5.5	5.4	5.3	5.2	5.1	6.4	6.2	6.1	5.9	5.8	5.7	5.6
	20	5.6	5.3	5.0	4.8	4.7	4.5	4.4	6.4	6.2	5.9	5.7	5.5	5.3	5.2
	40	4.8	4.5	4.3	4.0	3.8	3.7	3.5	5.7	5.3	5.1	4.9	4.7	4.5	4.4
	75	4.1	3.8	3.5	3.3	3.1	3.0	2.9	4.9	4.6	4.3	4.1	3.9	3.7	3.6
	90	3.9	3.5	3.3	3.1	3.0	2.8	2.7	4.7	4.4	4.1	3.9	3.7	3.5	3.4
200 x 63	10	6.4	6.2	6.0	5.9	5.8	5.6	5.5	7.1	6.9	6.7	6.6	6.4	6.2	6.0
	20	5.9	5.6	5.4	5.2	5.0	4.9	4.8	6.9	6.6	6.3	6.1	5.9	5.7	5.6
	40	5.2	4.9	4.7	4.5	4.3	4.1	3.9	6.1	5.7	5.5	5.2	5.1	4.9	4.8
	75	4.5	4.2	3.9	3.7	3.5	3.4	3.2	5.3	5.0	4.7	4.5	4.3	4.1	4.0
	90	4.3	3.9	3.7	3.5	3.3	3.2	3.0	5.1	4.8	4.5	4.3	4.1	3.9	3.8
240 x 45	10	6.8	6.6	6.4	6.3	6.1	6.0	5.8	7.5	7.3	7.1	7.0	6.8	6.6	6.4
	20	6.3	6.0	5.7	5.5	5.3	5.2	5.0	7.4	7.0	6.7	6.5	6.3	6.1	5.9
	40	5.5	5.2	4.9	4.7	4.6	4.4	4.2	6.5	6.1	5.8	5.5	5.4	5.2	5.0
	75	4.8	4.5	4.2	4.0	3.8	3.6	3.5	5.6	5.3	5.0	4.8	4.6	4.5	4.3
	90	4.6	4.2	4.0	3.7	3.6	3.4	3.3	5.4	5.0	4.8	4.6	4.4	4.2	4.0
240 x 63	10	7.4	7.1	6.9	6.7	6.5	6.4	6.2	8.3	8.1	7.9	7.7	7.4	7.1	6.9
	20	6.7	6.4	6.1	5.9	5.7	5.6	5.4	7.9	7.5	7.2	6.9	6.7	6.5	6.4
	40	5.9	5.6	5.3	5.1	4.9	4.8	4.7	6.9	6.5	6.2	6.0	5.8	5.6	5.5
	75	5.2	4.9	4.6	4.4	4.2	4.0	3.9	6.1	5.7	5.4	5.2	5.0	4.8	4.7
	90	5.0	4.7	4.4	4.2	4.0	3.8	3.6	5.8	5.5	5.2	5.0	4.8	4.6	4.5
300 x 45	10	8.2	7.8	7.6	7.4	7.2	7.0	6.8	-	-	-	-	8.0	7.8	7.5
	20	7.4	7.0	6.7	6.5	6.3	6.1	5.9	-	-	7.8	7.6	7.3	7.1	6.9
	40	6.5	6.1	5.8	5.6	5.4	5.2	5.1	7.6	7.1	6.8	6.5	6.3	6.1	5.9
	75	5.6	5.3	5.0	4.8	4.6	4.5	4.3	6.6	6.2	5.9	5.6	5.4	5.3	5.1
	90	5.4	5.1	4.8	4.6	4.4	4.2	4.1	6.3	5.9	5.6	5.4	5.2	5.0	4.7
300 x 63	10	8.5	8.2	8.0	7.8	7.6	7.4	7.3	-	-	-	-	-	-	-
	20	7.8	7.4	7.1	6.9	6.7	6.5	6.4	-	-	-	8.1	7.8	7.6	7.5
	40	6.9	6.5	6.2	6.0	5.8	5.6	5.5	8.1	7.6	7.3	7.0	6.8	6.6	6.4
	75	6.1	5.7	5.4	5.2	5.0	4.9	4.7	7.1	6.7	6.4	6.1	5.9	5.7	5.5
	90	5.8	5.5	5.2	5.0	4.8	4.7	4.5	6.8	6.4	6.1	5.8	5.6	5.5	5.3

FOR DETERMINATION OF ROOF LOAD WIDTH - SEE THE DIAGRAM BELOW.

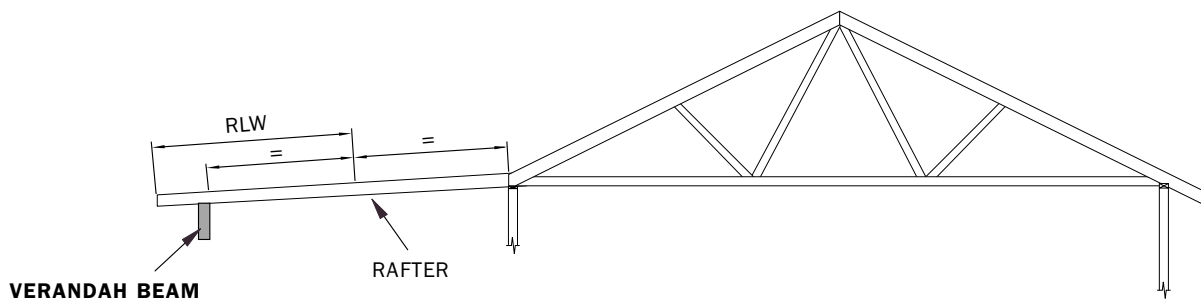

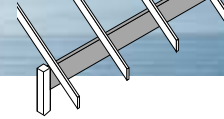

# VERANDAH BEAMS

Design Wind Speed 41 m/s

Design Deflection Limits  
 D.L. L.L.  
 SPAN/300 SPAN/300  
 OR 15 mm OR 15 mm

HYSPAN SECTION D X B (mm)	ROOF MASS kg/m <sup>2</sup>	SINGLE SPAN							CONTINUOUS SPAN						
		ROOF LOAD WIDTH 'RLW' (m)													
		0.9	1.2	1.5	1.8	2.1	2.4	2.7	0.9	1.2	1.5	1.8	2.1	2.4	2.7
MAXIMUM SPAN (m)															
130 x 36	10	3.2	3.1	2.8	2.6	2.4	2.2	2.1	3.8	3.2	2.9	2.6	2.4	2.3	2.2
	20	3.2	3.1	2.9	2.7	2.5	2.3	2.2	3.8	3.4	3.0	2.7	2.5	2.4	2.2
	40	3.1	2.8	2.6	2.5	2.3	2.2	2.2	3.8	3.5	3.2	3.0	2.7	2.6	2.4
	75	2.5	2.3	2.1	2.0	1.9	1.8	1.8	3.1	2.8	2.6	2.5	2.4	2.3	2.2
	90	2.4	2.2	2.0	1.9	1.8	1.7	1.7	2.9	2.7	2.5	2.3	2.2	2.1	2.0
130 x 45	10	3.6	3.5	3.4	3.1	2.9	2.7	2.5	4.2	3.9	3.5	3.2	3.0	2.8	2.6
	20	3.6	3.5	3.4	3.2	3.0	2.8	2.6	4.2	4.1	3.6	3.3	3.1	2.9	2.7
	40	3.3	3.0	2.8	2.6	2.5	2.4	2.3	4.0	3.7	3.5	3.3	3.1	3.0	2.9
	75	2.7	2.5	2.3	2.2	2.1	2.0	1.9	3.3	3.0	2.8	2.7	2.5	2.4	2.3
	90	2.5	2.3	2.2	2.0	1.9	1.9	1.8	3.1	2.9	2.7	2.5	2.4	2.3	2.2
130 x 63	10	4.2	4.0	3.9	3.8	3.5	3.2	3.1	4.8	4.6	4.2	3.9	3.6	3.3	3.1
	20	4.2	3.8	3.3	3.6	3.5	3.3	3.2	4.8	4.6	4.4	4.0	3.7	3.4	3.2
	40	3.6	3.3	3.1	2.9	2.8	2.7	2.6	4.5	4.1	3.8	3.6	3.5	3.3	3.2
	75	3.0	2.7	2.5	2.4	2.3	2.2	2.1	3.7	3.4	3.2	3.0	2.8	2.7	2.6
	90	2.8	2.6	2.4	2.3	2.2	2.1	2.0	3.5	3.2	3.0	2.8	2.7	2.6	2.5
150 x 36	10	3.9	3.5	3.2	2.9	2.7	2.5	2.4	4.2	3.6	3.3	3.0	2.7	2.6	2.4
	20	3.9	3.7	3.3	3.0	2.8	2.6	2.4	4.4	3.8	3.4	3.1	2.8	2.7	2.5
	40	3.5	3.2	3.0	2.8	2.7	2.6	2.5	4.3	4.0	3.6	3.3	3.1	2.9	2.7
	75	2.9	2.6	2.5	2.3	2.2	2.1	2.0	3.6	3.3	3.0	2.9	2.7	2.6	2.5
	90	2.7	2.5	2.3	2.2	2.1	2.0	1.9	3.4	3.1	2.9	2.7	2.6	2.5	2.3
150 x 45	10	4.3	4.2	3.9	3.5	3.3	3.0	2.9	4.9	4.4	4.0	3.6	3.3	3.1	2.9
	20	4.3	4.2	4.0	3.6	3.4	3.1	3.0	4.9	4.6	4.1	3.7	3.5	3.2	3.0
	40	3.8	3.4	3.2	3.0	2.9	2.8	2.7	4.6	4.3	4.0	3.8	3.6	3.4	3.3
	75	3.1	2.8	2.6	2.5	2.4	2.3	2.2	3.8	3.5	3.3	3.1	2.9	2.8	2.7
	90	2.9	2.7	2.5	2.3	2.2	2.1	2.1	3.6	3.3	3.1	2.9	2.8	2.6	2.5
150 x 63	10	4.9	4.8	4.7	4.3	4.0	3.7	3.5	5.4	5.3	4.9	4.5	4.1	3.8	3.6
	20	4.9	4.6	4.4	4.2	4.0	3.8	3.6	5.4	5.3	5.1	4.6	4.3	4.0	3.8
	40	4.2	3.8	3.6	3.4	3.2	3.1	3.0	5.0	4.7	4.4	4.2	4.0	3.8	3.7
	75	3.4	3.1	2.9	2.8	2.6	2.5	2.4	4.3	3.9	3.6	3.4	3.3	3.1	3.0
	90	3.3	3.0	2.8	2.6	2.5	2.4	2.3	4.0	3.7	3.4	3.2	3.1	2.9	2.8
170 x 36	10	4.5	3.9	3.5	3.2	2.9	2.7	2.6	4.6	4.0	3.6	3.3	3.0	2.8	2.7
	20	4.6	4.0	3.6	3.3	3.0	2.8	2.7	4.8	4.1	3.7	3.4	3.1	2.9	2.7
	40	4.0	3.6	3.4	3.2	3.0	2.9	2.8	4.8	4.5	4.0	3.6	3.4	3.2	3.0
	75	3.3	3.0	2.8	2.6	2.5	2.4	2.3	4.0	3.7	3.4	3.2	3.1	2.9	2.8
	90	3.1	2.8	2.6	2.5	2.3	2.2	2.2	3.8	3.5	3.2	3.0	2.9	2.7	2.6
170 x 45	10	4.9	4.8	4.3	3.9	3.6	3.4	3.2	5.5	4.9	4.4	4.0	3.7	3.5	3.3
	20	4.9	4.7	4.4	4.0	3.7	3.5	3.3	5.5	5.1	4.6	4.2	3.8	3.6	3.4
	40	4.2	3.9	3.6	3.4	3.3	3.1	3.0	5.0	4.7	4.5	4.2	4.0	3.9	3.7
	75	3.5	3.2	3.0	2.8	2.7	2.6	2.5	4.3	4.0	3.7	3.5	3.3	3.2	3.0
	90	3.3	3.0	2.8	2.7	2.5	2.4	2.3	4.1	3.7	3.5	3.3	3.1	3.0	2.9
170 x 63	10	5.5	5.3	5.2	4.9	4.6	4.3	4.0	6.1	5.9	5.6	5.1	4.7	4.4	4.1
	20	5.3	5.0	4.8	4.6	4.5	4.3	4.1	6.1	5.9	5.6	5.2	4.8	4.5	4.3
	40	4.6	4.3	4.0	3.8	3.6	3.5	3.4	5.4	5.1	4.9	4.7	4.5	4.3	4.2
	75	3.9	3.6	3.3	3.1	3.0	2.9	2.8	4.7	4.4	4.1	3.9	3.7	3.5	3.4
	90	3.6	3.3	3.1	3.0	2.8	2.7	2.6	4.5	4.2	3.9	3.7	3.5	3.3	3.2

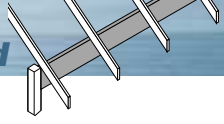

# VERANDAH BEAMS

Design Wind Speed 41 m/s

Design Deflection Limits  
 D.L. L.L.  
 SPAN/300 SPAN/300  
 OR 15 mm OR 15 mm

HYSPAN SECTION D X B (mm)	ROOF MASS kg/m <sup>2</sup>	SINGLE SPAN							CONTINUOUS SPAN						
		ROOF LOAD WIDTH 'RLW' (m)													
		0.9	1.2	1.5	1.8	2.1	2.4	2.7	0.9	1.2	1.5	1.8	2.1	2.4	2.7
MAXIMUM SPAN (m)															
200 x 36	10	5.1	4.4	3.9	3.6	3.3	3.1	2.9	5.2	4.5	4.0	3.7	3.4	3.2	3.0
	20	5.3	4.5	4.1	3.7	3.4	3.2	3.0	5.4	4.7	4.2	3.8	3.5	3.3	3.1
	40	4.6	4.3	4.0	3.8	3.6	3.4	3.2	5.4	5.1	4.5	4.1	3.8	3.5	3.3
	75	3.8	3.5	3.3	3.1	2.9	2.8	2.7	4.7	4.3	4.0	3.8	3.6	3.3	3.2
	90	3.6	3.3	3.1	2.9	2.8	2.6	2.5	4.5	4.1	3.8	3.5	3.3	3.1	2.9
200 x 45	10	5.7	5.5	4.9	4.5	4.1	3.9	3.6	6.4	5.6	5.0	4.6	4.2	4.0	3.7
	20	5.6	5.3	5.0	4.6	4.3	4.0	3.8	6.4	5.9	5.2	4.8	4.4	4.1	3.9
	40	4.8	4.5	4.3	4.0	3.8	3.7	3.5	5.7	5.3	5.1	4.9	4.7	4.4	4.2
	75	4.1	3.8	3.5	3.3	3.1	3.0	2.9	4.9	4.6	4.3	4.1	3.9	3.7	3.6
	90	3.9	3.5	3.3	3.1	3.0	2.8	2.7	4.7	4.4	4.1	3.9	3.7	3.5	3.4
200 x 63	10	6.4	6.2	6.0	5.8	5.4	5.0	4.7	7.1	6.9	6.6	6.0	5.5	5.1	4.8
	20	5.9	5.6	5.4	5.2	5.0	4.9	4.8	6.9	6.6	6.3	6.1	5.7	5.3	5.0
	40	5.2	4.9	4.7	4.5	4.3	4.1	3.9	6.1	5.7	5.5	5.2	5.1	4.9	4.8
	75	4.5	4.2	3.9	3.7	3.5	3.4	3.2	5.3	5.0	4.7	4.5	4.3	4.1	4.0
	90	4.3	3.9	3.7	3.5	3.3	3.2	3.0	5.1	4.8	4.5	4.3	4.1	3.9	3.8
240 x 45	10	6.8	6.4	5.7	5.2	4.8	4.5	4.2	7.5	6.5	5.8	5.3	4.9	4.6	4.3
	20	6.3	6.0	5.7	5.3	4.9	4.6	4.3	7.4	6.8	6.0	5.5	5.1	4.7	4.5
	40	5.5	5.2	4.9	4.7	4.6	4.4	4.2	6.5	6.1	5.8	5.5	5.4	5.1	4.8
	75	4.8	4.5	4.2	4.0	3.8	3.6	3.5	5.6	5.3	5.0	4.8	4.6	4.5	4.3
	90	4.6	4.2	4.0	3.7	3.6	3.4	3.3	5.4	5.0	4.8	4.6	4.4	4.2	4.0
240 x 63	10	7.4	7.1	6.9	6.7	6.5	6.0	5.7	8.3	8.1	7.8	7.1	6.6	6.1	5.8
	20	6.7	6.4	6.1	5.9	5.7	5.6	5.4	7.9	7.5	7.2	6.9	6.7	6.3	6.0
	40	5.9	5.6	5.3	5.1	4.9	4.8	4.7	6.9	6.5	6.2	6.0	5.8	5.6	5.5
	75	5.2	4.9	4.6	4.4	4.2	4.0	3.9	6.1	5.7	5.4	5.2	5.0	4.8	4.7
	90	5.0	4.7	4.4	4.2	4.0	3.8	3.6	5.8	5.5	5.2	5.0	4.8	4.6	4.5
300 x 45	10	8.2	7.3	6.5	5.9	5.5	5.1	4.8	-	7.7	6.9	6.3	5.8	5.4	5.1
	20	7.4	7.0	6.7	6.1	5.7	5.3	5.0	-	8.0	7.1	6.5	6.0	5.6	5.3
	40	6.5	6.1	5.8	5.6	5.4	5.2	5.1	7.6	7.1	6.8	6.5	6.3	6.1	5.7
	75	5.6	5.3	5.0	4.8	4.6	4.5	4.3	6.6	6.2	5.9	5.6	5.4	5.3	5.1
	90	5.4	5.1	4.8	4.6	4.4	4.2	4.1	6.3	5.9	5.6	5.4	5.2	5.0	4.7
300 x 63	10	8.5	8.2	8.0	7.8	7.6	7.1	6.7	-	-	-	-	8.0	7.4	7.0
	20	7.8	7.4	7.1	6.9	6.7	6.5	6.4	-	-	-	8.1	7.8	7.6	7.3
	40	6.9	6.5	6.2	6.0	5.8	5.6	5.5	8.1	7.6	7.3	7.0	6.8	6.6	6.4
	75	6.1	5.7	5.4	5.2	5.0	4.9	4.7	7.1	6.7	6.4	6.1	5.9	5.7	5.5
	90	5.8	5.5	5.2	5.0	4.8	4.7	4.5	6.8	6.4	6.1	5.8	5.6	5.5	5.3

FOR DETERMINATION OF ROOF LOAD WIDTH - SEE THE DIAGRAM BELOW.

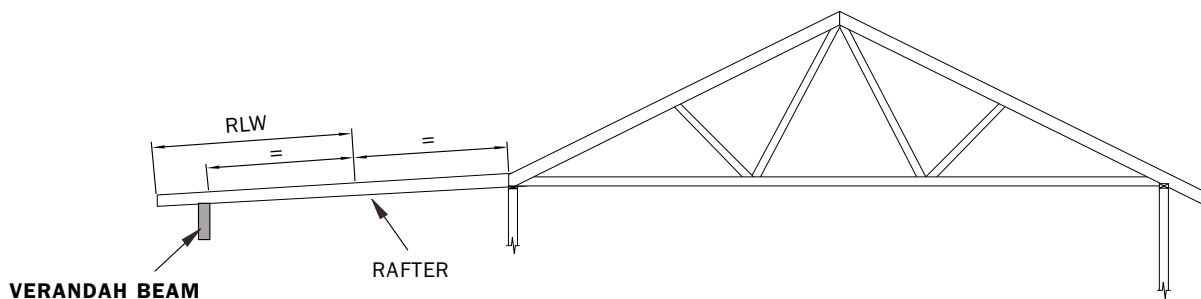

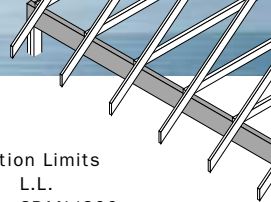

# GARAGE ROOF PITCHING BEAMS

For Trussed or Pitched Roofs

Design Deflection Limits  
 D.L. L.L.  
 SPAN/300 SPAN/300  
 OR 15 mm OR 12.5 mm

HYSPAN SECTION D X B (mm)	SHEET ROOF AND CEILING													
	ROOF LOAD WIDTH 'RLW' (m)													
	1.5	1.8	2.1	2.4	2.7	3.0	3.3	3.6	3.9	4.2	4.8	5.4	6.0	6.6
	MAXIMUM SINGLE SPAN (m)													
170 x 45	3.6	3.4	3.3	3.1	3.0	2.9	2.8	2.8	2.7	2.6	2.5	2.4	2.3	2.3
200 x 36	4.0	3.8	3.6	3.4	3.3	3.2	3.0	2.9	2.8	2.7	2.5	2.4	2.2	2.1
200 x 45	4.3	4.0	3.8	3.7	3.5	3.4	3.3	3.2	3.2	3.1	2.9	2.8	2.7	2.7
200 x 63	4.7	4.5	4.3	4.1	3.9	3.8	3.7	3.6	3.5	3.4	3.3	3.2	3.1	3.0
240 x 45	4.9	4.7	4.6	4.4	4.2	4.1	4.0	3.9	3.8	3.7	3.5	3.4	3.2	3.1
240 x 63	5.3	5.1	4.9	4.8	4.7	4.5	4.4	4.3	4.2	4.1	3.9	3.8	3.7	3.6
300 x 45	5.8	5.6	5.4	5.2	5.1	4.9	4.8	4.7	4.5	4.4	4.1	3.8	3.6	3.5
300 x 63	6.2	6.0	5.8	5.6	5.5	5.3	5.2	5.1	5.0	4.9	4.8	4.7	4.5	4.4
300 x 75	6.5	6.2	6.0	5.8	5.7	5.6	5.4	5.3	5.2	5.2	5.0	4.9	4.7	4.6
360 x 63	7.1	6.8	6.6	6.4	6.2	6.1	6.0	5.9	5.8	5.7	5.5	5.3	5.2	5.1
400 x 45	7.1	6.8	6.6	6.1	5.8	5.4	5.2	5.0	4.8	4.6	4.3	4.0	3.8	3.6
400 x 63	7.6	7.3	7.1	6.9	6.7	6.6	6.4	6.3	6.2	6.1	5.9	5.8	5.6	5.5
400 x 75	7.9	7.6	7.4	7.2	7.0	6.8	6.7	6.6	6.5	6.4	6.2	6.0	5.9	5.7
2/400 x 45*	8.2	7.9	7.7	7.5	7.3	7.1	7.0	6.8	6.7	6.6	6.1	5.8	5.4	5.2
450 x 63	8.3	8.0	7.7	7.5	7.3	7.2	7.0	6.9	6.8	6.7	6.5	6.3	6.1	5.9
2/450 x 63*	9.4	9.1	8.8	8.6	8.4	8.3	8.1	8.0	7.9	7.7	7.5	7.3	7.2	7.0
	MAXIMUM CONTINUOUS SPAN (m)													
200 x 45	5.1	4.9	4.7	4.5	4.4	4.2	4.1	3.9	3.8	3.7	3.4	3.2	3.0	2.9
200 x 63	5.5	5.2	5.1	4.9	4.8	4.7	4.6	4.5	4.3	4.2	4.0	3.8	3.6	3.4
240 x 45	5.8	5.5	5.4	5.2	5.0	4.9	4.8	4.6	4.4	4.3	4.0	3.8	3.7	3.5
240 x 63	6.2	6.0	5.8	5.6	5.5	5.3	5.2	5.1	5.0	4.9	4.8	4.6	4.3	4.1
300 x 45	6.8	6.5	6.3	6.1	5.9	5.8	5.6	5.4	5.2	5.1	4.8	4.5	4.3	4.2
300 x 63	7.3	7.0	6.8	6.6	6.4	6.3	6.1	6.0	5.9	5.8	5.6	5.5	5.3	5.2
300 x 75	7.6	7.3	7.1	6.9	6.7	6.5	6.4	6.3	6.1	6.0	5.9	5.7	5.6	5.4
360 x 63	8.3	8.0	7.7	7.5	7.3	7.2	7.0	6.9	6.7	6.6	6.4	6.3	6.1	6.0
400 x 45	-	8.0	7.8	7.5	7.2	6.9	6.6	6.4	6.2	6.0	5.7	5.4	5.2	5.0
400 x 63	-	-	-	8.1	7.9	7.7	7.6	7.4	7.3	7.2	6.9	6.8	6.6	6.4
400 x 75	-	-	-	-	-	8.0	7.9	7.7	7.6	7.4	7.2	7.0	6.9	6.7

\*Size built-up by vertical nail lamination - see page 5.

FOR DETERMINATION OF ROOF LOAD WIDTH REFER TO THE DIAGRAMS BELOW.

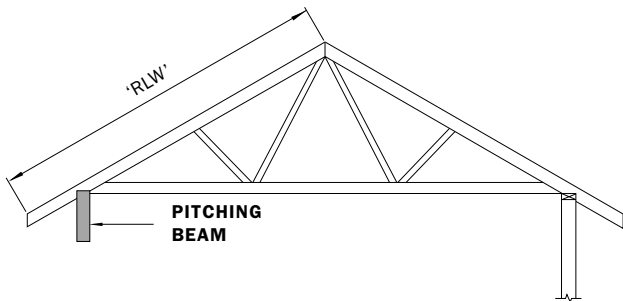

TRUSSED ROOF

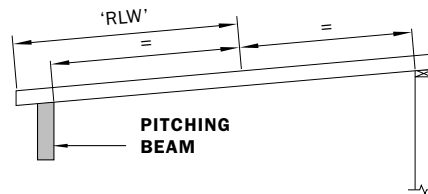

SKILLION ROOF

Garage Roof Pitching Beams

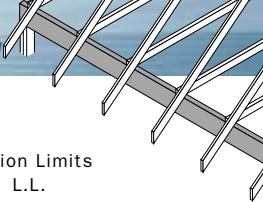

Design Deflection Limits  
 D.L. L.L.  
 SPAN/300 SPAN/300  
 OR 15 mm OR 12.5 mm

# GARAGE ROOF PITCHING BEAMS

For Trussed or Pitched Roofs

HYSPAN SECTION D X B (mm)	TILE ROOF AND CEILING													
	ROOF LOAD WIDTH 'RLW' (m)													
	1.5	1.8	2.1	2.4	2.7	3.0	3.3	3.6	3.9	4.2	4.8	5.4	6.0	6.6
	MAXIMUM SINGLE SPAN (m)													
170 x 45	2.8	2.7	2.5	2.4	2.3	2.2	2.2	2.1	2.1	2.0	1.9	1.9	1.8	1.7
200 x 36	3.1	2.9	2.8	2.6	2.5	2.5	2.4	2.3	2.3	2.2	2.1	2.0	1.9	1.9
200 x 45	3.3	3.1	3.0	2.8	2.7	2.6	2.6	2.5	2.4	2.4	2.3	2.2	2.1	2.0
200 x 63	3.7	3.5	3.3	3.2	3.0	2.9	2.9	2.8	2.7	2.6	2.5	2.4	2.3	2.3
240 x 45	4.0	3.7	3.6	3.4	3.3	3.2	3.1	3.0	2.9	2.8	2.7	2.6	2.5	2.4
240 x 63	4.4	4.2	4.0	3.8	3.6	3.5	3.4	3.3	3.2	3.2	3.0	2.9	2.8	2.7
300 x 45	4.8	4.6	4.4	4.2	4.1	3.9	3.8	3.7	3.6	3.5	3.4	3.3	3.1	3.1
300 x 63	5.2	5.0	4.8	4.7	4.5	4.4	4.3	4.1	4.0	3.9	3.8	3.6	3.5	3.4
300 x 75	5.4	5.2	5.0	4.9	4.7	4.6	4.5	4.4	4.3	4.2	4.0	3.8	3.7	3.6
360 x 63	5.9	5.7	5.5	5.3	5.2	5.1	4.9	4.8	4.8	4.7	4.5	4.4	4.2	4.1
400 x 45	5.9	5.7	5.5	5.3	5.2	5.0	4.9	4.8	4.7	4.7	4.4	4.1	3.9	3.8
400 x 63	6.4	6.2	5.9	5.8	5.6	5.5	5.3	5.2	5.1	5.0	4.9	4.8	4.6	4.5
400 x 75	6.7	6.4	6.2	6.0	5.8	5.7	5.6	5.5	5.4	5.3	5.1	5.0	4.8	4.7
2/400 x 45*	6.9	6.7	6.4	6.3	6.1	5.9	5.8	5.7	5.6	5.5	5.3	5.2	5.0	4.9
450 x 63	7.0	6.7	6.5	6.3	6.1	6.0	5.8	5.7	5.6	5.5	5.3	5.2	5.1	4.9
2/450 x 63*	8.1	7.8	7.5	7.3	7.2	7.0	6.8	6.7	6.6	6.5	6.3	6.1	6.0	5.8
	MAXIMUM CONTINUOUS SPAN (m)													
200 x 45	4.1	3.9	3.7	3.5	3.4	3.3	3.2	3.1	3.0	2.9	2.8	2.7	2.6	2.5
200 x 63	4.5	4.3	4.1	3.9	3.8	3.6	3.5	3.4	3.3	3.3	3.1	3.0	2.9	2.8
240 x 45	4.8	4.6	4.4	4.2	4.0	3.9	3.8	3.7	3.6	3.5	3.4	3.2	3.1	3.0
240 x 63	5.2	5.0	4.8	4.6	4.5	4.4	4.2	4.1	4.0	3.9	3.7	3.6	3.5	3.4
300 x 45	5.6	5.4	5.2	5.0	4.9	4.8	4.7	4.6	4.5	4.3	4.1	3.9	3.7	3.6
300 x 63	6.1	5.8	5.6	5.5	5.3	5.2	5.1	5.0	4.9	4.8	4.6	4.5	4.3	4.2
300 x 75	6.3	6.1	5.9	5.7	5.5	5.4	5.3	5.2	5.1	5.0	4.8	4.7	4.6	4.5
360 x 63	7.0	6.7	6.4	6.3	6.1	5.9	5.8	5.7	5.6	5.5	5.3	5.1	5.0	4.9
400 x 45	7.0	6.7	6.4	6.2	6.0	5.7	5.5	5.4	5.2	5.1	4.9	4.7	4.5	4.3
400 x 63	7.5	7.2	7.0	6.8	6.6	6.4	6.3	6.1	6.0	5.9	5.7	5.6	5.4	5.3
400 x 75	7.8	7.5	7.3	7.0	6.8	6.7	6.5	6.4	6.3	6.2	6.0	5.8	5.7	5.5

\*Size built-up by vertical nail lamination - see page 5.

FOR DETERMINATION OF ROOF LOAD WIDTH REFER TO THE DIAGRAMS BELOW.

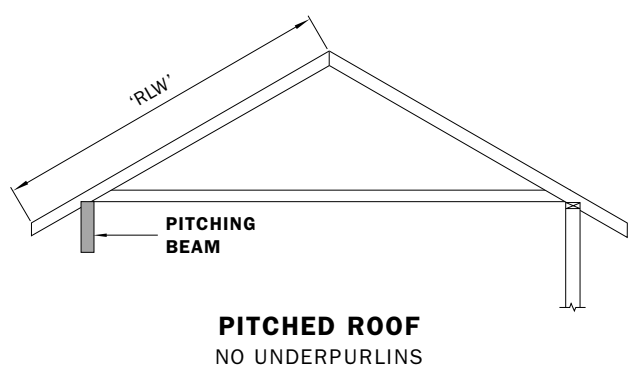
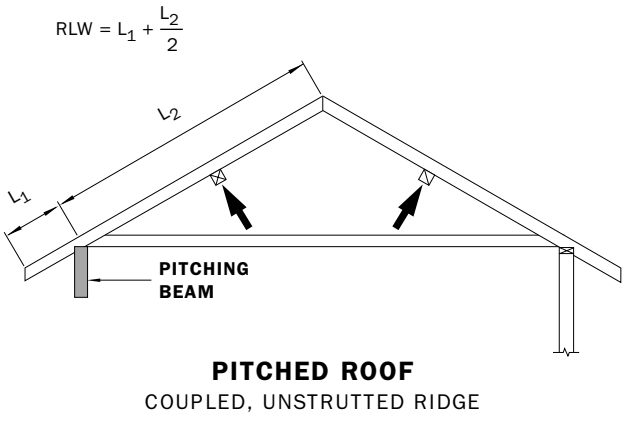

Garage Roof Pitching Beams

# GARAGE ROOF STRUTTING BEAMS

*Strutting Beam Beneath Ceiling*

## DETERMINATION OF ROOF LOAD WIDTH 'RLW'.

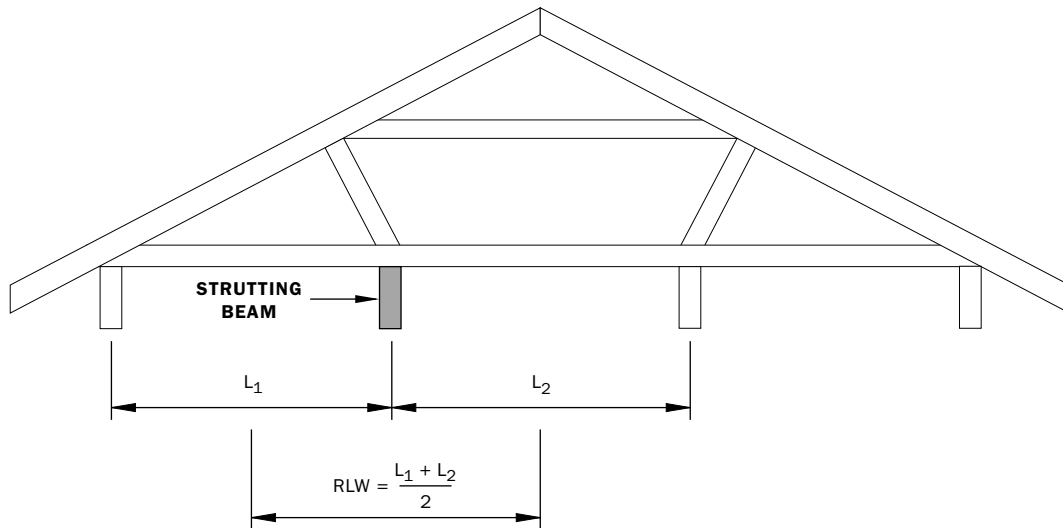

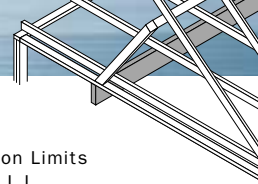

# GARAGE ROOF STRUTTING BEAMS

*Strutting Beam Beneath Ceiling*

Design Deflection Limits  
 D.L. L.L.  
 SPAN/300 SPAN/300  
 OR 20 mm OR 12.5 mm

HYSPAN SECTION D X B (mm)	SHEET ROOF AND CEILING									
	ROOF LOAD WIDTH 'RLW' (m) - see below									
	1.5	1.8	2.1	2.4	2.7	3.0	3.3	3.6	3.9	4.2
	MAXIMUM SPAN (m)									
240 x 63	5.7	5.4	5.1	4.9	4.7	4.6	4.5	4.3	4.2	4.1
300 x 45	6.3	6.0	5.7	5.5	5.3	5.1	5.0	4.9	4.7	4.6
300 x 63	6.7	6.5	6.3	6.1	5.9	5.7	5.5	5.4	5.3	5.1
300 x 75	7.0	6.7	6.5	6.3	6.2	6.0	5.8	5.7	5.6	5.4
2/300 x 45*	7.2	7.0	6.8	6.6	6.4	6.3	6.1	6.0	5.9	5.7
360 x 63	7.6	7.4	7.1	6.9	6.8	6.6	6.5	6.3	6.2	6.1
400 x 45	7.7	7.4	7.2	6.9	6.8	6.6	6.5	6.3	6.2	6.1
400 x 63	8.2	7.9	7.7	7.5	7.3	7.1	7.0	6.8	6.7	6.6
400 x 75	8.5	8.2	8.0	7.8	7.6	7.4	7.2	7.1	7.0	6.9
2/400 x 45*	8.8	8.5	8.3	8.0	7.9	7.7	7.5	7.4	7.3	7.2
450 x 63	8.9	8.6	8.4	8.1	7.9	7.7	7.6	7.4	7.3	7.2
2/450 x 63*	10.1	9.8	9.5	9.3	9.1	8.9	8.8	8.6	8.5	8.4
525 x 75	10.3	9.9	9.6	9.4	9.2	9.0	8.8	8.6	8.5	8.4
	TILE ROOF AND CEILING									
240 x 63	4.5	4.2	4.0	3.8	3.7	3.6	3.5	3.4	3.3	3.2
300 x 45	5.0	4.7	4.5	4.3	4.1	4.0	3.9	3.8	3.7	3.6
300 x 63	5.5	5.2	5.0	4.8	4.6	4.5	4.3	4.2	4.1	4.0
300 x 75	5.8	5.5	5.3	5.0	4.9	4.7	4.6	4.4	4.3	4.2
2/300 x 45*	6.1	5.8	5.6	5.3	5.2	5.0	4.8	4.7	4.6	4.5
360 x 63	6.4	6.2	6.0	5.7	5.5	5.3	5.2	5.0	4.9	4.8
400 x 45	6.4	6.2	5.9	5.7	5.5	5.3	5.2	5.0	4.9	4.8
400 x 63	7.0	6.7	6.4	6.3	6.1	5.9	5.7	5.6	5.4	5.3
400 x 75	7.2	6.9	6.7	6.5	6.3	6.2	6.0	5.9	5.7	5.6
2/400 x 45*	7.5	7.2	7.0	6.8	6.6	6.4	6.3	6.2	6.1	5.9
450 x 63	7.6	7.3	7.0	6.8	6.6	6.5	6.3	6.2	6.1	6.0
2/450 x 63*	8.8	8.4	8.2	8.0	7.8	7.6	7.4	7.3	7.1	7.0
525 x 75	8.8	8.4	8.2	7.9	7.7	7.5	7.4	7.2	7.1	7.0

\*Size built-up by vertical nail lamination - see page 5.

FOR DETERMINATION OF ROOF LOAD WIDTH - SEE THE DIAGRAM ON PAGE 66.



## APPENDIX

### 1. ROOF SLOPE CONVERSION

The following table gives a slope factor 'C' that can be used in the formulae given, to convert distances on the slope 'L<sub>1</sub>' to the horizontal distance 'L<sub>2</sub>' (or vice versa) for a roof slope 'θ'.

ROOF SLOPE, 'θ'	5°	10°	15°	20°	25°	30°	35°	40°	45°
SLOPE FACTOR 'C'	1.00	1.02	1.04	1.06	1.10	1.16	1.22	1.31	1.41

Interpolation for intermediate roof pitches will give an approximately correct result.

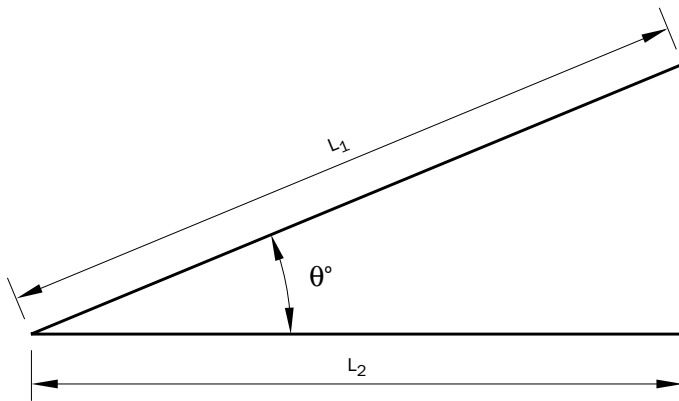

#### Formulae for conversion

$$L_1 = C \times L_2$$

$$L_2 = \frac{L_1}{C}$$

### 2. MASS OF TYPICAL FRAMING TIMBERS

FRAMING SIZE (mm)	MASS PER UNIT LENGTH kg/m	MASS PER UNIT AREA (kg/m <sup>2</sup> ) FOR FRAMING SPACED AT			
		450	600	900	1200
70 X 35 PINE	1.3	2.9	2.2	1.5	1.1
75 X 38 HWD	3.0	6.7	5.0	3.3	2.5
70 X 45 PINE	1.7	3.8	2.8	1.9	1.4
75 X 50 HWD	3.9	8.8	6.6	4.4	3.3
90 X 35 PINE	1.7	3.8	2.8	1.9	1.4
100 X 38 HWD	4.0	8.9	6.7	4.4	3.3
90 X 45 PINE	2.2	4.9	3.6	2.4	1.8
100 X 50 HWD	5.3	11.7	8.8	5.8	4.4
120 X 35 PINE	2.3	5.0	3.8	2.5	1.9
125 X 38 HWD	5.0	11.1	8.3	5.5	4.2
120 X 45 PINE	2.9	6.5	4.9	3.2	2.4
125 X 50 HWD	6.6	14.6	10.9	7.3	5.5
140 X 35 PINE	2.6	5.9	4.4	2.9	2.2
150 X 38 HWD	6.0	13.3	10.0	6.7	5.0
140 X 45 PINE	3.4	7.6	5.7	3.8	2.8
150 X 50 HWD	7.9	17.5	13.1	8.8	6.6
190 X 35 PINE	3.6	8.0	6.0	4.0	3.0
200 X 38 HWD	8.0	17.7	13.3	8.9	6.7
190 X 45 PINE	4.6	10.3	7.7	5.1	3.8
200 X 50 HWD	10.5	23.3	17.5	11.7	8.8

HWD is unseasoned hardwood, density 1050 kg/m<sup>3</sup>

PINE is seasoned softwood, density 540 kg/m<sup>3</sup>

## HYSPAN SPECIFICATION

Hyspan is structural laminated veneer lumber manufactured in accordance with AS/NZS 4357 and having the structural design properties specified in the adjacent table.

### Veneer

Thickness (nominal)	3.2mm	
Species	Radiata Pine	
Grade	D	AS/NZS 2269
Joints Face	Scarf	
Joints Other	Butt/Scarf	

**Moisture Content:** 7% - 15%

### Dimensional Tolerances:

Length	- 0mm, + 20mm
Depth to 450mm	- 0mm, + 2mm
Thickness	- 0mm, + 3mm

**Density:** 620 kg/m<sup>3</sup> (approximately)

**Adhesive:** Type "A" Marine Bond (Phenolic)  
Refer AS 2098 and AS 2754

**Finish:** Unsanded Faces, Sawn Edges

**Branding:** Each piece of Hyspan shall be branded at least once with the Hyspan, PAA and JAS-ANZ logos for identification and evidence of compliance with manufacturing quality control standards.

### LIMIT STATE PROPERTIES FOR DESIGN WITH HYSPAN

LIMIT STATE PROPERTIES FOR DESIGN WITH HYSPAN		
<b>Elastic Moduli</b>		
Modulus of elasticity	E	13,200 MPa
Modulus of rigidity	G	660 MPa
<b>Characteristic Strengths</b>		
Bending	f <sub>b</sub>	48 MPa
Tension parallel to grain	f <sub>t</sub>	33 MPa
Compression parallel to grain	f <sub>c</sub>	45 MPa
Shear in beams	f <sub>s</sub>	5.3 MPa
Compression perpendicular to grain	f <sub>p</sub>	12 MPa
Shear at joint details	f <sub>sj</sub>	5.3 MPa
<b>Joint group</b>		JD4

Note: Further design information and guidance for Limit State Design is available in the futurebuild publication 'Limit States Design with Hyspan'.



*Long length Hyspan rafters for house under construction at Eltham, Victoria.*

## STANDARD HYSPAN SECTIONS AND THEIR APPROXIMATE MASS

95 x 36	2.2 kg/m	95 x 45	2.8 kg/m	90 x 63	3.5 kg/m	150 x 75	7.2 kg/m
130 x 36	3.0	130 x 45	4.2	95 x 63	3.8	300 x 75	14.4
150 x 36	3.5	150 x 45	4.4	130 x 63	5.2	400 x 75	19.2
170 x 36	4.0	170 x 45	5.0	150 x 63	6.0	525 x 75	25.2
200 x 36	4.7	200 x 45	5.8	170 x 63	6.9	600 x 75	28.8
240 x 36	5.6	240 x 45	6.9	200 x 63	8.0		
		300 x 45	8.6	240 x 63	9.7		
		360 x 45	10.4	300 x 63	12.1		
90 x 42	2.4 kg/m	400 x 45	11.5	360 x 63	14.5		
				400 x 63	16.1		
				450 x 63	18.1		
				600 x 63	24.1		

All sizes available in lengths to 13.2 metres, longer lengths and other sizes available subject to enquiry.

---

**Available From:**

---

22 Prospect Street  
PO Box 425  
Box Hill Victoria 3128  
Australia

General Enquiries  
Freecall 1800 284 792  
Facsimile (08) 8739 7313

Technical Enquiries  
Freecall 1800 808 131  
Facsimile (03) 9793 9727

[www.chhfuturebuild.com](http://www.chhfuturebuild.com)

 **futurebuild**

A Carter Holt Harvey Business